

Host RS-232 Connector

Table 1 provides information for connecting the Host computer to the On-Board IS Controller.

Table 1: Host RS-232 Connector Specifications

Parameter	Value
Baud Rate	9.6 kbs
Data Bits	7
Parity	Even
Number of Stop Bits	0

NOTE: The Host computer RS-232 cable must be fully shielded through to the outer shell. Use CTI-Cryogenics cable 8132157 or equivalent.

Startup

See the 8040647, *On-Board IS Cryopump Operation Instructions*, for details.

Status LEDs

Status LED III blinks when the On-Board IS Controller is operating, and indicates normal Intercomponent Network communication. Status LED I and LED II remain off during normal operation.

Helium Mapping

A helium map is a collection of cryopumps and compressors that the On-Board IS Controller manages, so that the system operates efficiently. The map controls when each cryopump uses a shared helium manifold and compressor for each process tool. See the *On-Board IS Cryopump System Operation Guide*, CTI-Cryogenics part number 8040647, for more information about helium maps.

To check the device (cryopumps and compressors) addresses in a helium map:

1. Make a physical inventory of the system, noting the address of each device.
2. Use the Remote keypad (part number 8187007K00, see Figure 3) to go to the *On-Board IS Controller* screen.
3. Choose *Monitor* and press *Enter*, choose *Show Devices* and then press *Enter*.
4. Ensure that all device addresses appear correctly.

If all device addresses match the physical inventory, continue to add or change a helium map. If the device addresses do not match, check the cable connections and repeat from [Step 2](#) through this step.

To change or add to a helium map:

1. Use the Remote keypad to go to the *On-Board IS Controller* screen.
2. Choose *System Setup* and press *Enter*, choose *Helium* and then press *Enter*, finally choose *Helium Map X* (where X is the number of the helium map you want to see) then press *Enter*. The *Choose Map Pumps* screen appears.
3. Choose the addresses of cryopumps that match your inventory addresses, go to *Accept Change*, and then press *Enter*. The *Choose Compressors* screen appears.
4. Choose the addresses of compressors that match your inventory addresses, go to *Accept Change*, and then press *Enter*. The *Verify Helium Map X* screen appears.
5. Go to *Accept Change* and press *Enter* to set the helium map.

If you want to make changes to the helium map, press the back button as necessary and make the changes.

Product Information and Technical Support

Please visit the Brooks Automation website at www.brooks.com or email to tscallcenter@brooks.com.

On-Board[®] IS Controller (Pump Mount) Quick Installation Guide

Part Number 8040648, Revision A, 01/11/2013

ECO Number 63723

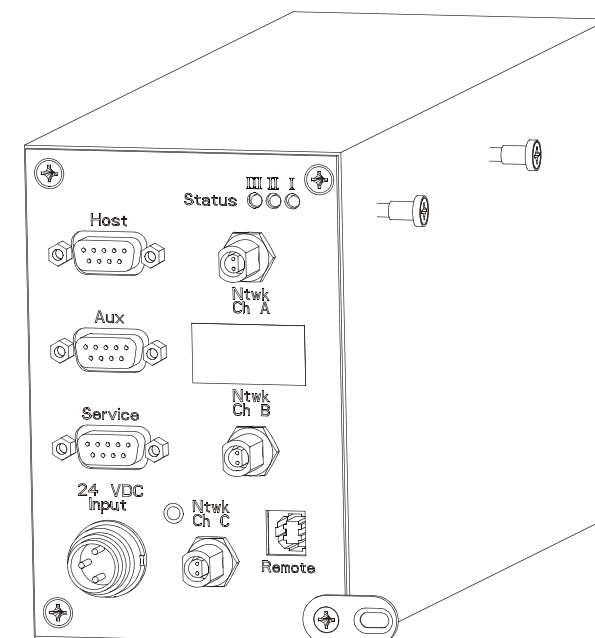

On-Board IS Controller Specifications

Input Voltage and Power: 24 VDC +/- 10% (21.6 - 26.4) VDC - 18 watts

Ambient Temperature: 50° F - 100° F (10° C - 38° C)

Communication Interface: Host RS-232, Aux RS-232, Service RS-232 - 9 Pin D Connector

Communication Interface Baud Rate: 9600

On-Board IS Intercomponent Network Interface: RS-232, RS-485

On-Board IS Remote Interface: USB B Connector with RS-232 Protocol

Before You Start

1. Ensure the On-Board IS Cryopumps are installed according to the appropriate On-Board IS Cryopump Quick Installation Guide.
2. Ensure the On-Board IS 1000 Compressors are installed according to 8040645, *On-Board IS 1000 Compressor Quick Installation Guide*.
3. Read and follow all safety precautions in this guide and in the appropriate cryopump and compressor guides.

On-Board IS Controller Installation

Install the On-Board IS Controller on the selected On-Board IS Cryopump as shown in *Figure 1*.

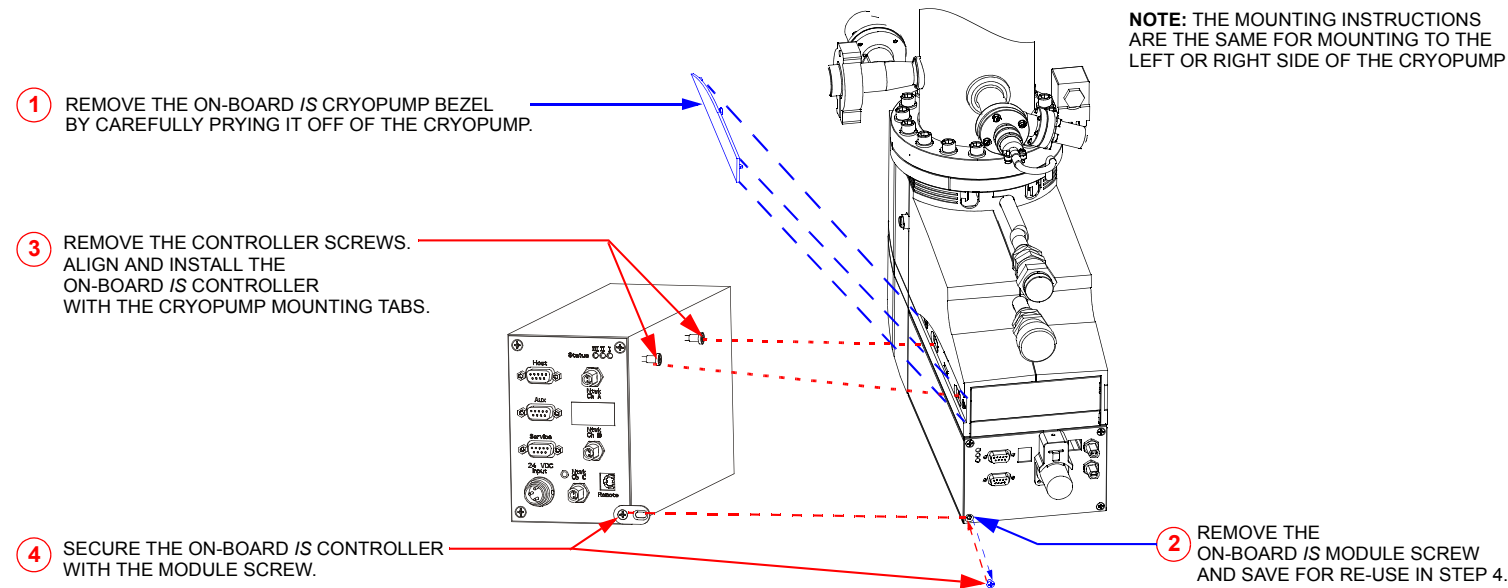
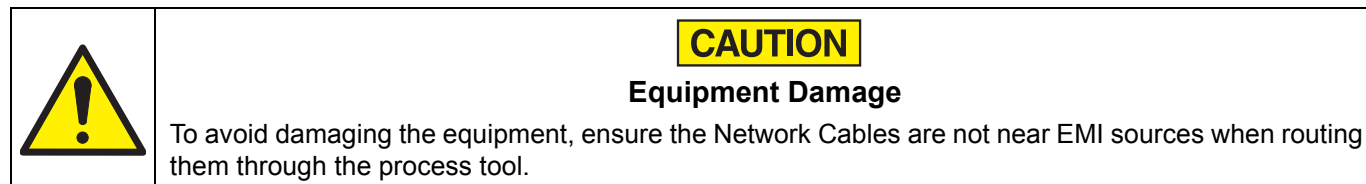

Figure 1: On-Board IS Controller Pump Mount Installation

On-Board IS Controller Cable Connections



1. Connect the Channel A Network Cables between the On-Board IS Controller and On-Board IS Cryopumps as shown in *Figure 2* and *Figure 3*.
2. Connect the Channel B Network Cables between the On-Board IS Controller and On-Board IS Cryopumps as shown in *Figure 2* and *Figure 3*.
3. Connect the Channel C Network Cables between the On-Board IS Controller and On-Board IS 1000 Compressors as shown in *Figure 2* and *Figure 3*.

NOTE: Make sure the last On-Board IS Cryopump and On-Board IS 1000 Compressor on each channel have a terminator installed in the open Network connector. Otherwise, data for that channel will not be visible on the On-Board IS Remote.

4. Connect a Terminator to the open Network terminal on the last On-Board IS device on each channel.
5. Connect the HOST computer RS-232 cable to the HOST connector on the On-Board IS Controller.
6. Connect the On-Board IS Remote cable to the REMOTE connector on the On-Board IS Controller front panel.
7. Connect the power supply power cable to a customer provided 24 VDC power source as shown in *Figure 2*. Status III (LED) blinks when the On-Board IS Controller is communicating with the network.

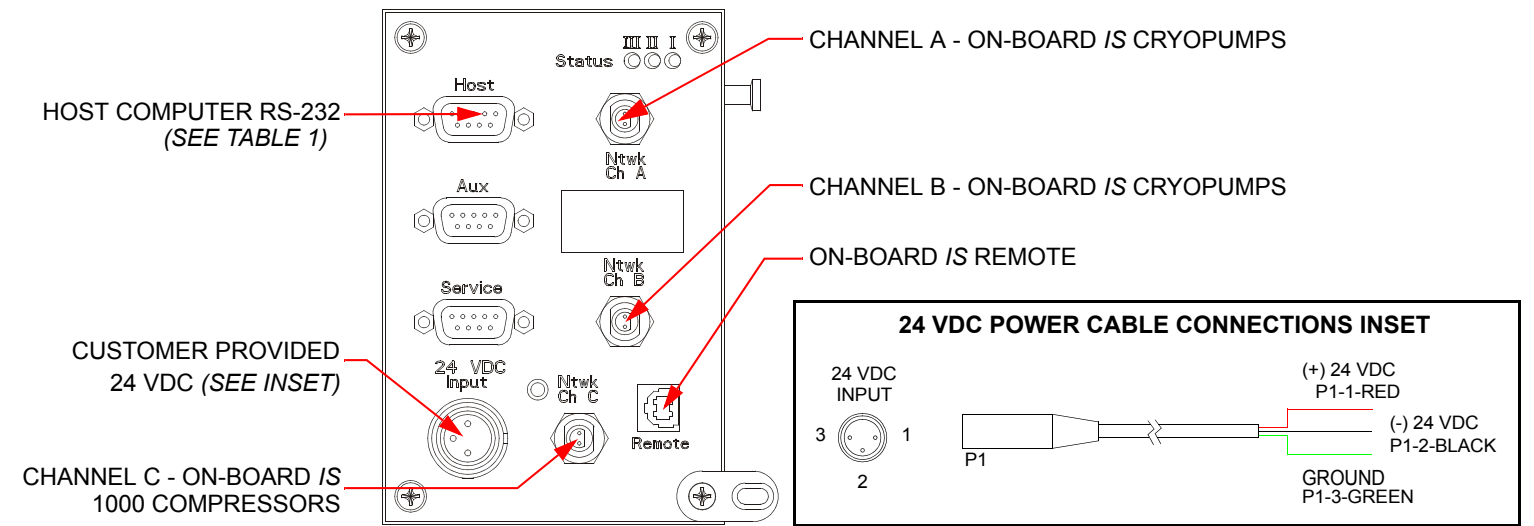

Figure 2: On-Board IS Controller Cable Connections

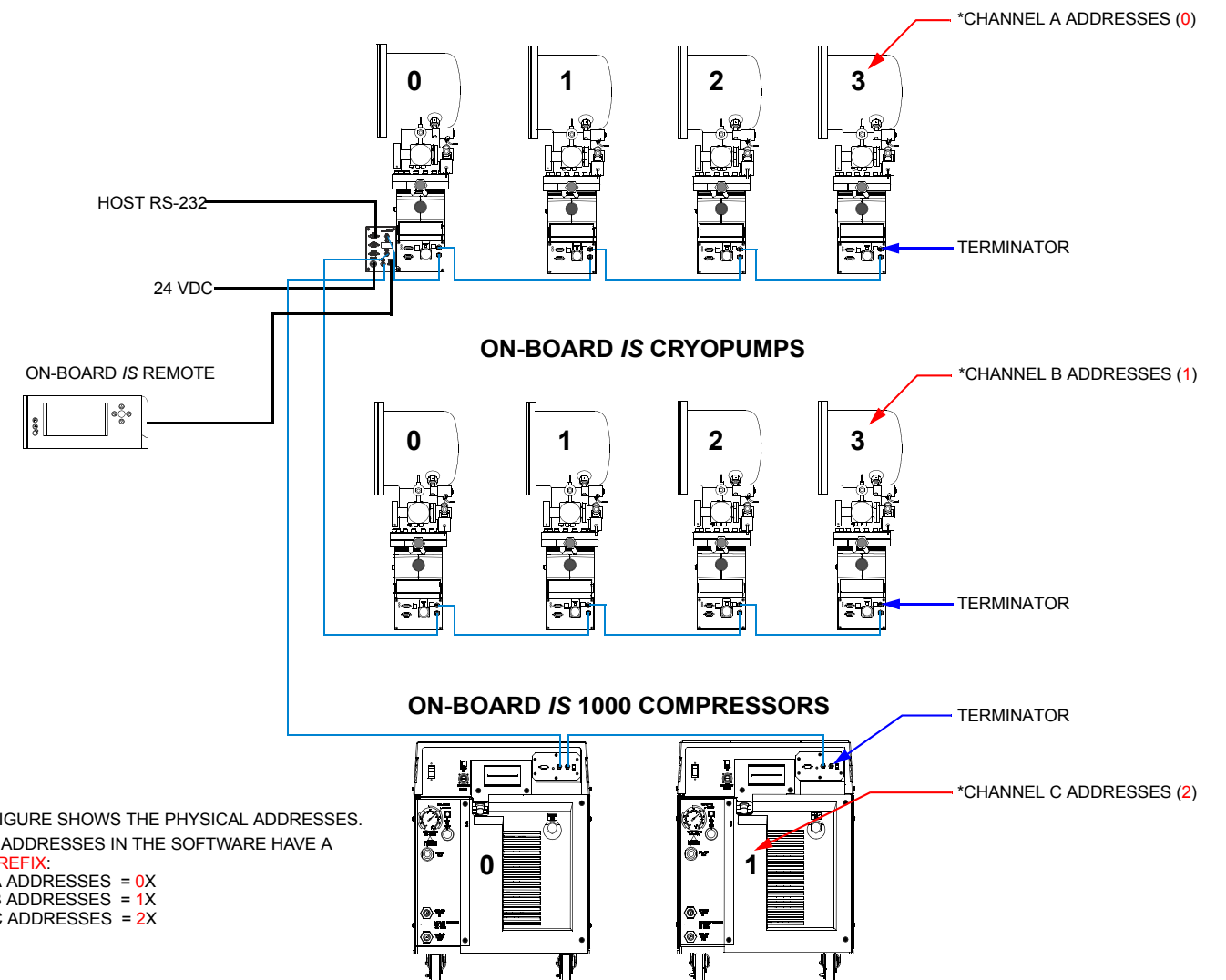

Figure 3: On-Board IS Cryopump and Network Connections