



On-Board[®] GLE Cryopump
Installation and Maintenance
Instructions

Information provided within this document is subject to change without notice, and although believed to be accurate, Brooks Automation assumes no responsibility for any errors, omissions, or inaccuracies.

AcuLigner™, Align™, AquaTran™, AutoTeach™, ATR™, AXM™, Basic Blue™, BiSymmetrik™, CenterSmart™, Cool Solutions™, Crate to Operate™, e-RMA™, e-Spares™, e-Volution™, FastRegen™, FIXLOAD™, FrogLeg™, InLigner™, InCooler™, Interface™, Jet Engine™, LowProfile™, M2 Nano™, Mini-Ion™, PASIV™, PowerPak™, PerformanceBlue™, PowerPak™, PowerTools™, QuadraFly™, Radius™, Radiant™, Radiant Express™, Reliance™, Reliance ATR™, RetroEase™, SCARA™, SmartPM™, SPOTLevel™, Synetics™, The New Pathway to Productivity™, Time Optimized Trajectory™, Time Optimal Trajectory™, Time Optimized Path™, TopCooler™, TopLigner™, Ultimate Blue™, VAC-407™, VacuTran™, Vacuum Quality Monitor™, VQM™, Vacuum Quality Index™, VQI™, and the Brooks logo are trademarks of Brooks Automation, Inc.

AcuTran®, AquaTrap®, Conductron®, Convector®, the Cool Solutions logo, Cryodyne®, Cryotiger®, Cryo-Torr®, Fusion®, GOLDLink®, Granville-Phillips®, Guardian®, GUTS®, Helix®, Jet®, Leapfrog®, MagnaTran®, MapTrak®, Marathon®, Marathon 2®, Marathon Express®, Micro-Ion®, MiniConvector®, On-Board®, Polycold®, Razor®, Simplicity Solutions®, the Simplicity Solutions logo, Stabil-Ion®, TrueBlue®, TurboPlus®, Vision®, Zaris®, and the Brooks Automation logo are registered U.S. trademarks of Brooks Automation, Inc.

All other trademarks are properties of their respective owners.

© 2013 Brooks Automation, Inc. All Rights Reserved. The information included in this manual is Proprietary Information of Brooks Automation and is provided for the use of Brooks Automation customers only and cannot be used for distribution, reproduction, or sale without the express written permission of Brooks Automation. This information may be incorporated into the user documentation, however any changes made by the user to this information is the responsibility of the user.



For Technical Support:

Location	GUTS® Contact Number
North America	+1-800-FOR-GUTS (1-800-367-4887) +1-978-262-2900
Europe	+49-1804-CALL-GUTS (+49-1804-2255-4887)
Japan	+81-45-477-5980
China	+86-21-5131-7066
Taiwan	+886-3-5525225
Korea	+82-31-288-2500
Singapore	+65-6464-1481

Visit us online: www.brooks.com

January 15, 2013 Part Num 8040564 Revision AA

This technology is subject to United States export Administration Regulations and authorized to the destination only; diversion contrary to U.S. law is prohibited.

Printed in the U.S.A.

Table of Contents

Safety Conventions

Introduction	S-1
Signal Word Descriptions	S-1
Safety Shape Descriptions	S-2
References	S-2

Section 1 - On-Board GLE Cryopump Description

Introduction	1-1
Installation, Operation, and Maintenance Instructions	1-1
Microprocessor-Based Control System	1-1
Power Conditioning Module Option	1-4
On-Board Vacuum Network Controller Module Option	1-6
Remote Operation Option	1-7
Specifications	1-8
Theory of Operation	1-9
Cold Head	1-10
Vacuum Vessel and Arrays	1-10
Compressor Gas and Oil Flows	1-10

Section 2 - Installation

Introduction	2-1
On-Board GLE Cryopump Installation	2-2
Vent Pipe Connection	2-2
Roughing Pump Connection	2-3
Rough Valve Gas Connection	2-3
Purge Gas Connection	2-4
Helium Line Connections	2-4
Auxiliary (AUX) TC Gauge Installation	2-4
Setpoint Relays	2-4
Remote Keypad/Display Installation (Optional)	2-7

Section 3 - Troubleshooting

Technical Inquiries	3-1
---------------------------	-----

Section 4 - Maintenance

Helium Circuit Decontamination	4-1
Background	4-2
Equipment/Tools Requirements	4-3
Method 1 - Decontaminate all On-Board GLE Cryopumps	4-6



Decontamination Alternatives	4-10
Method #1 Decontaminate All Cryopumps	4-10
Method # 2 Decontamination of Only Cold Cryopumps	4-11
Method # 3 Grouped Decontamination using Manifold	4-11
On-Board GLE Cryopump Cleaning	4-14

Appendix A - Customer Support Information

Customer Support Center Locations	A-1
Guaranteed Up-Time Support (GUTS)	A-1
Product Information	A-1
E-mail	A-1

Index

List of Figures

List of Tables

List of Figures

Figure 1-1: On-Board 8 and On-Board 8 GLE Cryopumps	1-3
Figure 1-2: On-Board 8F GLE Cryopump with PCM	1-5
Figure 1-3: On-Board 8F GLE Cryopump with Optional On-Board Vacuum Network Controller Module	1-6
Figure 1-4: Typical On-Board 8 GLE Cryopump System	1-12
Figure 1-5: Cutaway View of a Typical On-Board 8F GLE Cryopump Vessel. . .	1-13
Figure 1-6: Typical Flat On-Board 8 GLE Cryopump Component Identification. .	1-14
Figure 1-7: Cutaway View of a Typical On-Board 8 GLE Cryopump Vessel. . .	1-15
Figure 1-8: Typical On-Board 8 Cryopump Component Identification	1-16
Figure 2-1: Block Diagram for On-Board GLE Cryopump Installation	2-1
Figure 2-2: Setpoint Relays Connector Pin Identification	2-6
Figure 4-1: Decontamination Flowchart	4-4
Figure 4-2: On-Board GLE Cryopump Helium Supply and Return Lines	4-8
Figure 4-3: Maintenance Manifold Part Number 8032051G001	4-13
Figure 4-4: Proper Helium Line Coupling Disconnection/Connection	4-14

This Page Left Intentionally Blank

List of Tables

Table 1-1:On-Board 8 GLE Cryopump Specifications	1-8
Table 1-2:On-Board 8F GLE Cryopump Specifications	1-9
Table 3-1:Cryopump Troubleshooting Procedures.	3-2
Table 3-1:Troubleshooting Procedures (continued).....	3-3
Table 4-1:Methods of Decontamination.....	4-1
Table 4-2:Decontamination Tools and Equipment.....	4-3

This Page Left Intentionally Blank

Safety Conventions

Introduction



Follow all safety precautions during installation, normal operation, and when servicing CTI-Cryogenics products.

This chapter explains the safety conventions used throughout this manual. CTI-Cryogenics uses a specific format for cautions and warnings, which includes standard signal words and safety shapes.

See also the *Customer Support* appendix or call your local Customer Support Center for assistance.



Signal Word Descriptions

All cautions and warnings contain signal words, which call attention to safety messages and designate the degree of hazard seriousness. The following table shows the signal words and their meanings that may be used in this document.

Term	Example	Definition
CAUTION		A signal word accompanied by a safety shape that indicates a potentially hazardous situation or unsafe practice. If not avoided, the action may result in minor or moderate personal injury or equipment damage . A CAUTION is highlighted in yellow.
CAUTION		A signal word that indicates a situation or unsafe practice, which if not avoided may result in equipment damage . A CAUTION is highlighted in yellow.
WARNING		A signal word accompanied by a safety shape that indicates indicates a potentially hazardous situation. If not avoided, the action may result in serious injury or death . A WARNING is highlighted in orange.

Safety Shape Descriptions

All cautions and warnings contain safety shapes, which have specific safety meanings. The following table shows some of the safety shapes used in this document and their meanings.

Example	Term	Shape Definition
	General Warning	Indicates a general hazard. Details about this hazard appear in the safety notice explanation.
	High Voltage	Indicates a high voltage hazard.
	Hot Surface	Indicates a surface is hot enough to cause discomfort or a burn.

References

For more information about safety standards, see the following documents:

- ISO 7010: 2003(E), Graphic symbols - Safety colours and safety signs - Safety signs used in workplaces and public areas
- ISO 3864-1: 2002(E), Graphic symbols - Safety colours and safety signs - Part 1: Design principles for safety signs in workplaces and public areas

Section 1 - On-Board GLE Cryopump Description

Introduction

On-Board GLE Cryopumps provide fast, clean pumping of all gases in the 10^{-3} to 10^{-9} torr range. They are available in two configurations; On-Board 8F (Flat) and On-Board 8 (Straight) as shown in [Figure 1-1](#).

On-Board Cryopumps operate on the principle that gases can be condensed and held at extremely low vapor pressures, achieving high speeds and throughputs as described in [Table 1-1](#).

On-Board Cryopumps are highly-reliable and rugged units that require little maintenance. Since the On-Board Cryopump exposes no moving parts, operating fluids, or backing pumps to the vacuum, the possibility of system or process contamination from the On-Board Cryopump is eliminated.

Installation, Operation, and Maintenance Instructions

On-Board 8 GLE Cryopump Installation, Operation, and Maintenance Instructions provide easily accessible information. All personnel with installation, operation, and maintenance responsibilities should become familiar with the contents of these instructions to ensure safe, reliable, and high performance.

Microprocessor-Based Control System

The On-Board 8 GLE Cryopump is equipped with a microprocessor-based control system that allows you to both monitor and control a wide range of important vacuum system functions. Operations are performed from either a remote keypad control/display panel that can be connected to the cryopump or from the production tool host computer. You can monitor and control cooldown, warm-up, regeneration, etc.

Refer to the **On-Board GLE Cryopump Module Programming and Operation Instructions** P/N 8040574 that came with your On-Board 8

GLE Cryopump, for a complete description of the numerous operational functions that are available.

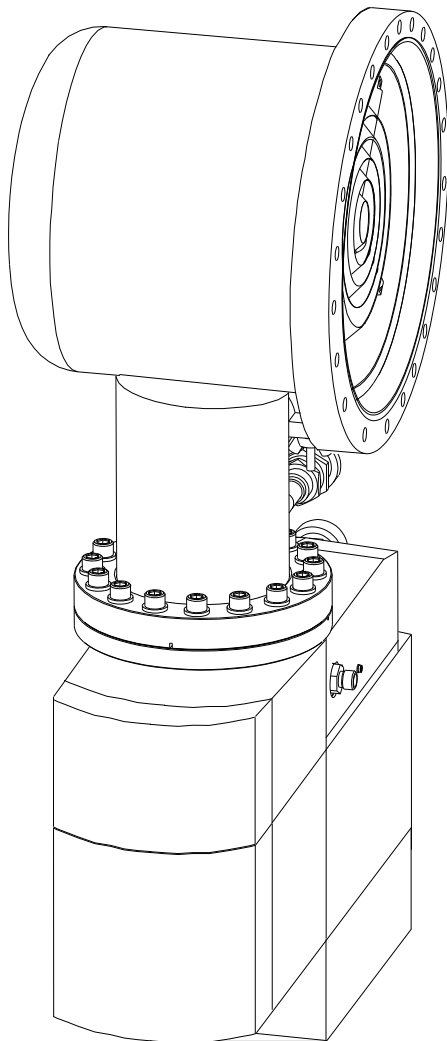

ON-BOARD 8F CRYOPUMP

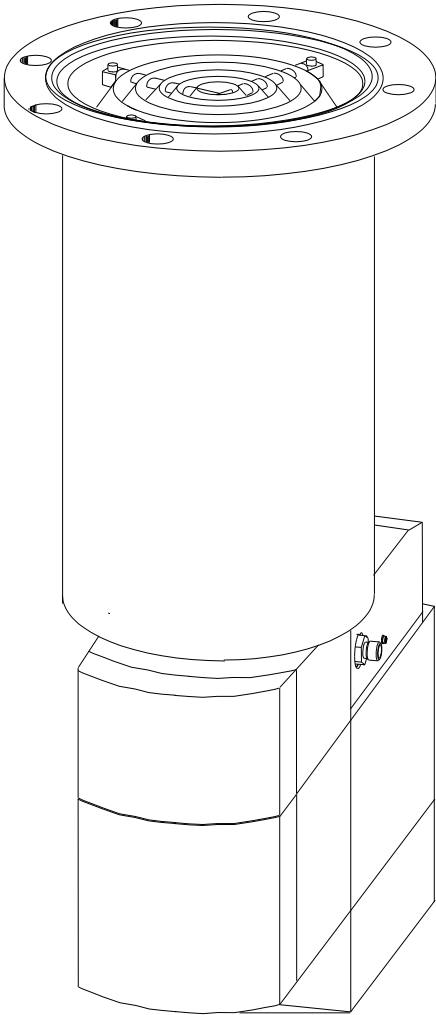

ON-BOARD 8 CRYOPUMP

Figure 1-1: On-Board 8 and On-Board 8 GLE Cryopumps

Power Conditioning Module Option

The Power Conditioning Module (PCM) provides power to the On-Board GLE Cryopump from a customer provided 208 VAC, 50/60 Hz, single phase power source. The PCM provides constant 3 phase 60 Hz power to the On-Board GLE Cryopump regardless of input AC line voltage and frequency fluctuations. The PCM is typically mounted under the

On-Board 8 GLE Cryopump Module to minimize the space required for installation.

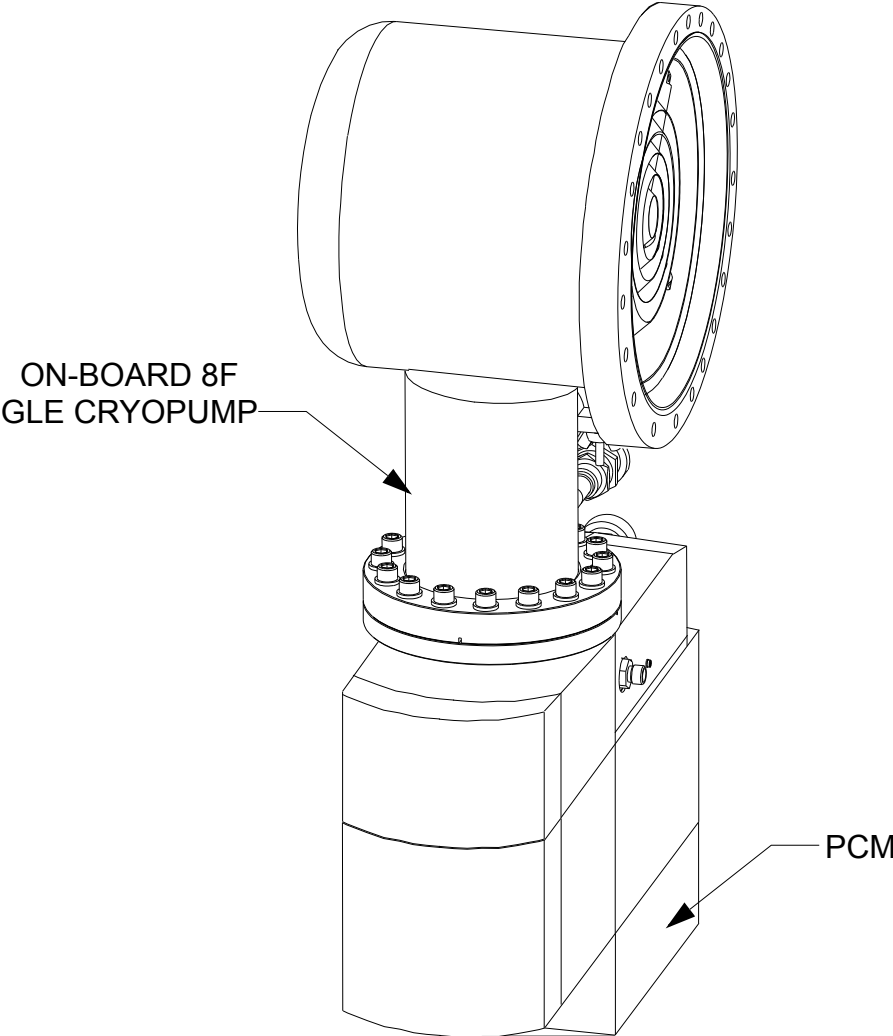

Figure 1-2: On-Board 8F GLE Cryopump with PCM

On-Board Vacuum Network Controller Module Option

The On-Board Vacuum Network Controller Module provides monitor and control capability of multiple On-Board Pumps, turbo pumps, valves and gauges from the production facility host computer.

The On-Board Vacuum Network Controller Module is typically mounted on either side of the On-Board 8 GLE Cryopump Module to minimize the space required for installation.

Refer to the **On-Board Vacuum Network Controller Module Installation and Operation Instructions**, Helix Technology Corporation P/N 8040565 for more information.

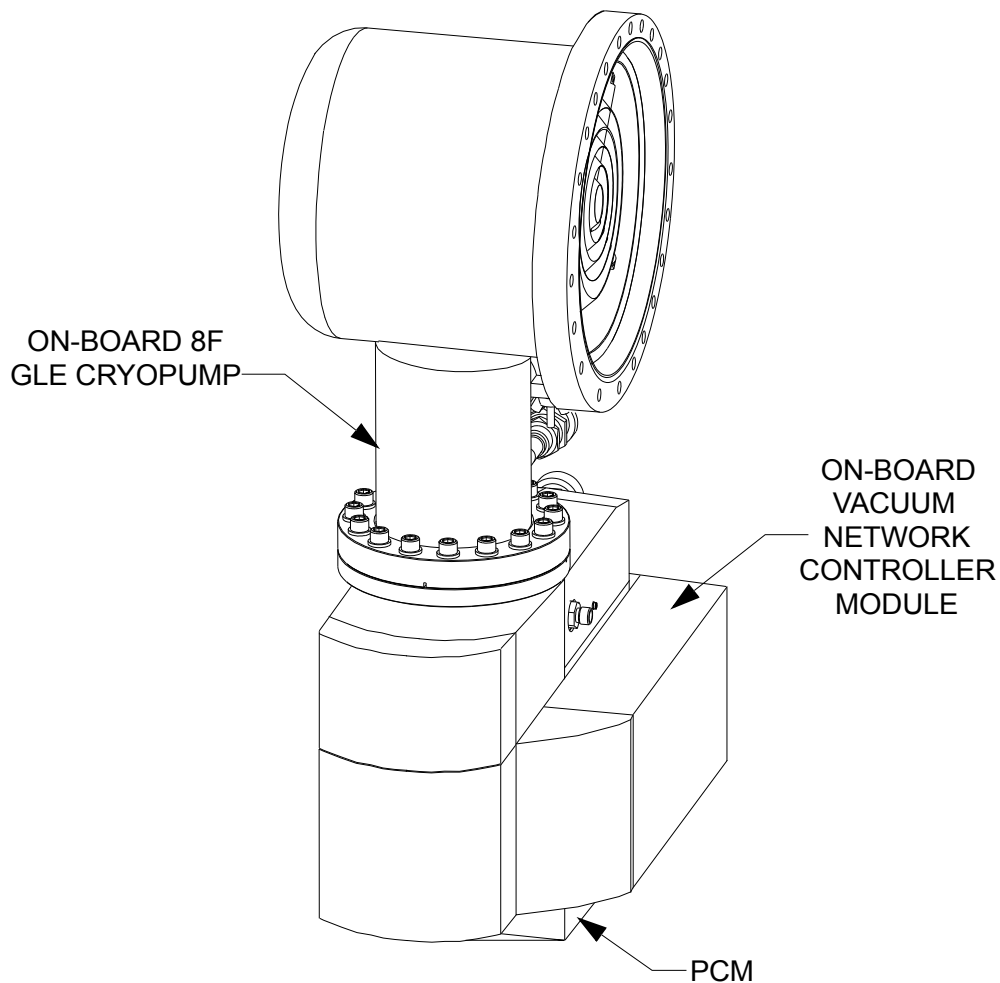

Figure 1-3: On-Board 8F GLE Cryopump with Optional On-Board Vacuum Network Controller Module

Remote Operation Option

On-Board 8 GLE Cryopumps can be controlled remotely using either a BITBUS™ or RS-232 protocol. The most common implementation, used in multiple On-Board 8 GLE Cryopump process tools, is to network the On-Board 8 GLE Cryopumps using the BITBUS™ protocol. In this configuration, the networked On-Board 8 GLE Cryopumps are managed as a group by the On-Board Vacuum Network Controller Module, which coordinates group regeneration cycles and provides a standardized communication link to the process tool host controller. Using this approach, control of the networked On-Board 8 GLE Cryopumps is fully integrated with process tool control.

Specifications

Table 1-1: On-Board 8 GLE Cryopump Specifications

Parameter	Specifications
Input Power	208 VAC 50/60 Hz
Rough Pump Connection	NW 25 ISO KF
Integrated Hardware	Keypad/Display Roughing Valve Purge Valve Cryopump TC Gauge 1st Stage Diode 2nd Stage Diode 1st Stage Heater 2nd Stage Heater 2 Setpoint Relays RS-232 Interface
Pumping Speeds:	
Water	4000 liters/sec
Air	1500 liters/sec
Hydrogen	2200 liters/sec
Argon	1200 liters/sec
Argon Throughput	700 sccm (9 torr-liters/sec)
Capacity:	
Argon	1000 std. liters
Hydrogen	12 std. liters @ 5×10^{-6} torr
Crossover	150 torr-liters
Cooldown Time	2 hours nominal
Dimensions	Refer to Installation/Interface Drawing
Weight	63 lbs.

Table 1-2: On-Board 8F GLE Cryopump Specifications

Parameter	Specifications
Input Power	208 VAC 50/60 Hz
Rough Pump Connection	NW 25 ISO KF
Integrated Hardware	Keypad/Display Roughing Valve Purge Valve Cryopump TC Gauge 1st Stage Diode 2nd Stage Diode 1st Stage Heater 2nd Stage Heater 2 Setpoint Relays RS-232 Interface
Pumping Speeds:	
Water	4000 liters/sec
Air	1500 liters/sec
Hydrogen	2500 liters/sec
Argon	1200 liters/sec
Argon Throughput	700 sccm (9 torr-liters/sec)
Capacity:	
Argon	1000 std. liters
Hydrogen	17 std. liters @ 5×10^{-6} torr
Crossover	150 torr-liters
Cooldown Time	2 hours nominal
Dimensions	Refer to Installation/Interface Drawing
Weight	60 lbs.

Theory of Operation

Each On-Board GLE Cryopump consists of a cold head and a vacuum vessel as shown in [Figure 1-4](#) or [Figure 1-5](#). An 80K condensing array, a 15K array, cold head station heaters, and an 80K radiation shield are located in the vacuum vessel. The cold station heaters and 15K array are secured to the cold head, which is welded to the vacuum vessel. The cold

head provides cooling to the three arrays. Gases are removed from your vacuum chamber, thereby creating a vacuum when they are condensed or adsorbed on the cryogenically-cooled arrays.

Cold Head

The cold head consists of a two-stage cold head cylinder (part of the vacuum vessel) and drive unit displacer assembly, that together produce closed-cycle refrigeration at temperatures that range from 60 to 120K for the first-stage cold station and 10 to 20K for the second-stage cold station, depending on operating conditions. Within the drive unit displacer assembly, the drive unit actuates the displacer-regenerator assembly located in the cold head cylinder and thereby controls the flow of helium into the cold head. Within the drive unit are located the crankcase and drive motor, which is a direct-drive constant-speed motor, operating at 72 rpm on 60 Hz power and 60 rpm on 50 Hz power.

During operation, high pressure helium from the compressor enters the cold head at the helium supply connector, and flows through the displacer-regenerator assembly, crankcase, and motor housing before exiting through the helium gas return connector and returning to the compressor. Helium expansion in the displacer-regenerator assembly provides cooling at the first and second stage cold stations.

Vacuum Vessel and Arrays

The 80K array, as shown in [Figure 1-4](#) or [Figure 1-5](#), condenses water and hydrocarbon vapors. The 15K array condenses nitrogen, oxygen, and argon while the specially processed charcoal of this array traps helium, hydrogen, and neon. The temperature of the cold head stations to which the 15K array and 80K radiation shield are attached, is measured by temperature sensors and transmitted to the On-Board controller for display.

Compressor Gas and Oil Flows

Helium returning from the cryopump cold head enters the compressor, and a small quantity of oil is injected into the gas stream, thereby overcoming helium's low specific heat and inability to carry heat produced during compression. Helium is then compressed and passed through a heat exchanger for removal of compression-caused heat.

The helium continues its flow through an oil-mist separator and a charcoal filter adsorber (cartridge), within the compressor, where oil and contaminants are removed. A differential pressure relief valve in the compressor limits the operating pressure differential between the helium supply and return lines, thereby allowing compressor operation without

cold head operation. When cold head operation reaches a steady-state condition, further pressure regulation is unnecessary.

A typical On-Board 8 GLE Cryopump system is shown in [Figure 1-3](#).

The location of helium and electrical components of typical flat and straight On-Board 8 GLE Cryopumps are shown in [Figure 1-6](#) and [Figure 1-7](#) respectively.

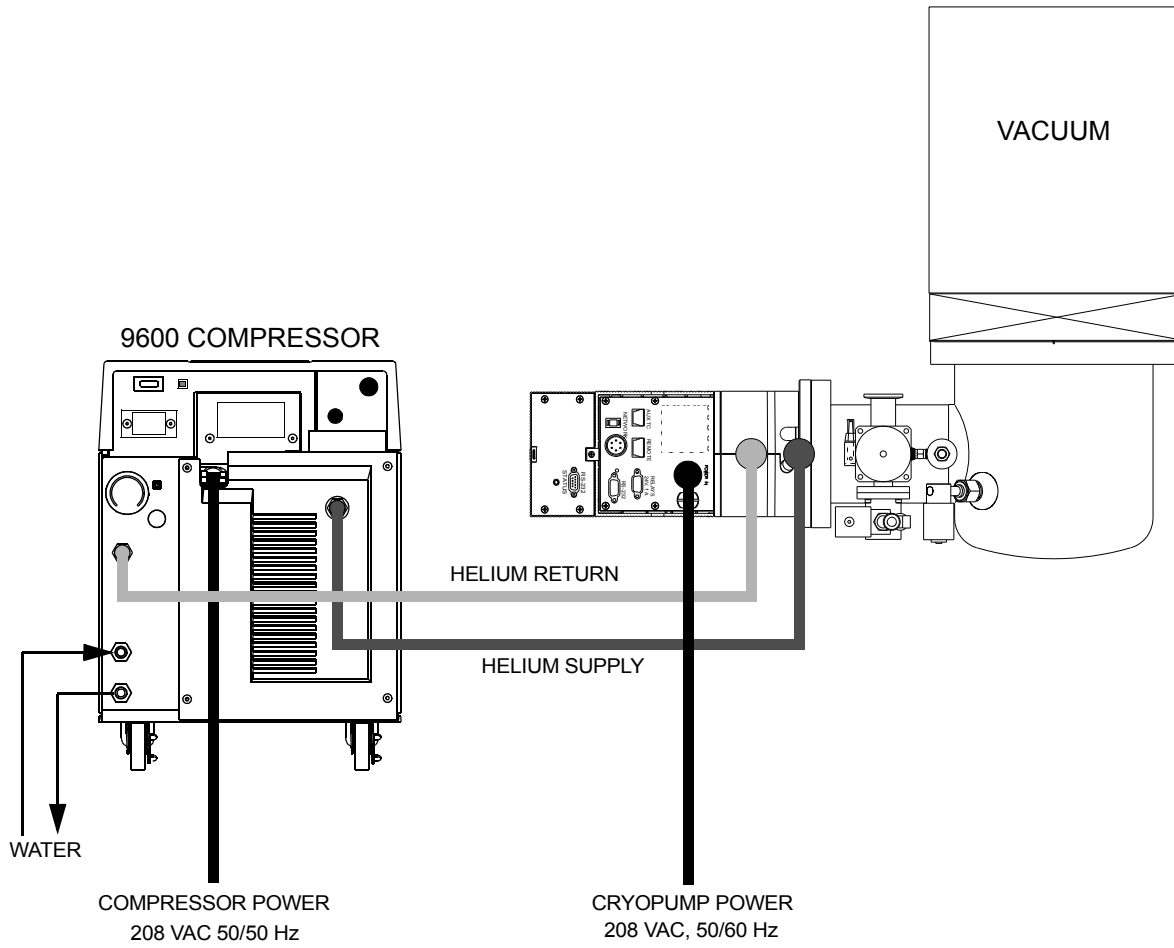

Figure 1-4: Typical On-Board 8 GLE Cryopump System

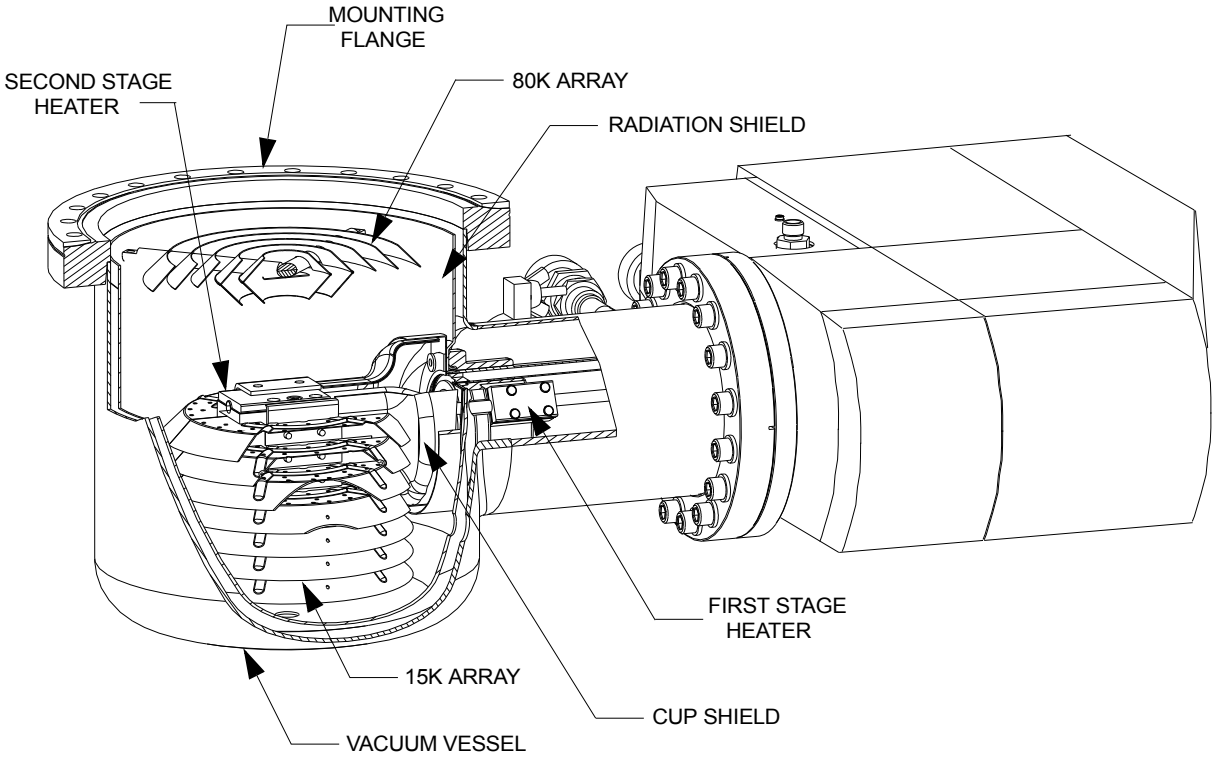
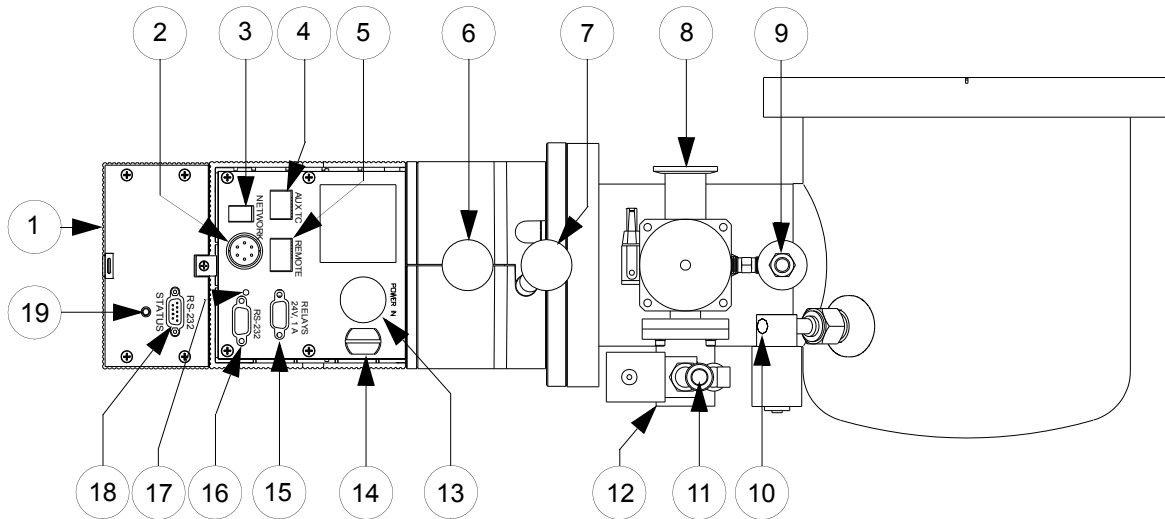

Figure 1-5: Cutaway View of a Typical On-Board 8F GLE Cryopump Vessel



LEGEND

1. Power Conditioning Module (PCM)
2. On-Board Network Connector
3. On-Board Network Pump Identification Switch
4. Auxiliary Thermocouple Gauge Connector
5. Remote Keypad Connector
6. Helium Return Connector
7. Helium Supply Connector
8. Rough Pump Connection
9. Air Supply Connection (60 - 80 psi, 1/8 NPT)
10. Purge Gas Connection (10 - 25 psig or 40 - 80 psig) 1/8 NPT
11. Exhaust Purge Valve Vent

Figure 1-6: Typical Flat On-Board 8 GLE Cryopump Component Identification

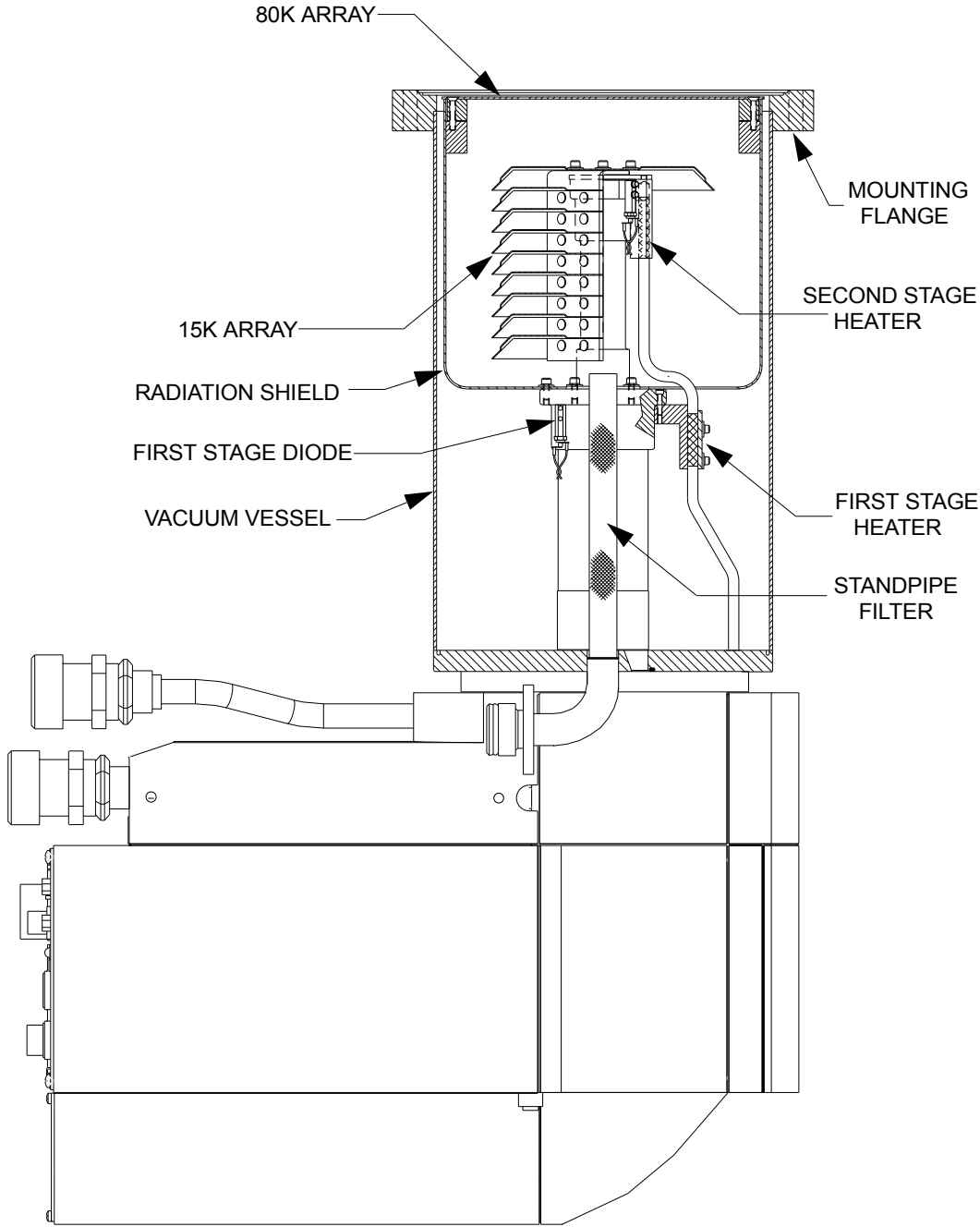
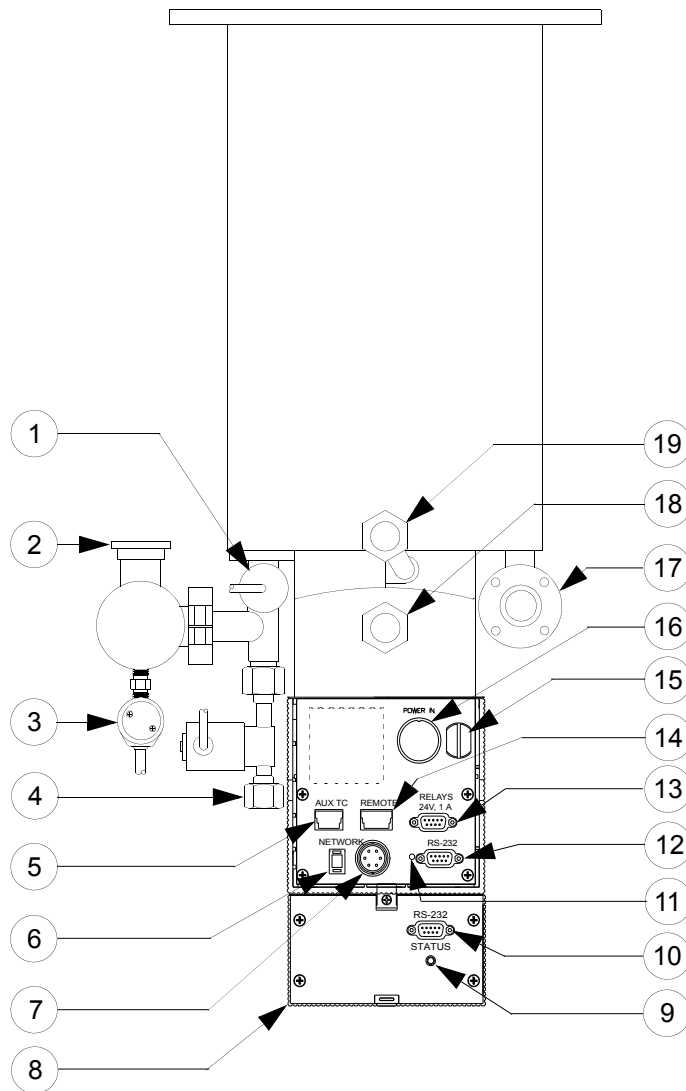

Figure 1-7: Cutaway View of a Typical On-Board 8 GLE Cryopump Vessel



LEGEND

- | | |
|--|--|
| 1. Thermocouple Gauge | 10. RS-232 Computer Interface Connector |
| 2. Rough Pump Connection | 11. Module Power Indicator Lamp |
| 3. Air Supply Connection (60 - 80 psig 1/8 NPT) | 12. RS-232 Computer Interface Connector |
| 4. Purge Gas Connection (10 - 25 psig or 40 - 80 psig 1/8 NPT) | 13. Relays Connector |
| 5. Auxiliary Thermocouple Gauge Connector | 14. Remote Keypad/Display Connector |
| 6. On-Board Network Pump Identification Switch | 15. On-Board Module Safety Interlock Screw |
| 7. On-Board Network Connector | 16. Input Power Connector |
| 8. Power Conditioning Module | 17. Pressure Relief Valve |
| 9. Status LED | 18. Helium Return Connector |
| | 19. Helium Supply Connector |

Figure 1-8: Typical On-Board 8 Cryopump Component Identification

Section 2 - Installation

Introduction

Installation information is presented for experienced and non-experienced On-Board GLE Cryopump system technicians. The flowchart in [Figure 2-1](#) highlights the major tasks of On-Board GLE Cryopump installation. Refer to [Figure 2-1](#) and the appropriate installation procedure within this section for the type of On-Board GLE Cryopump being installed.

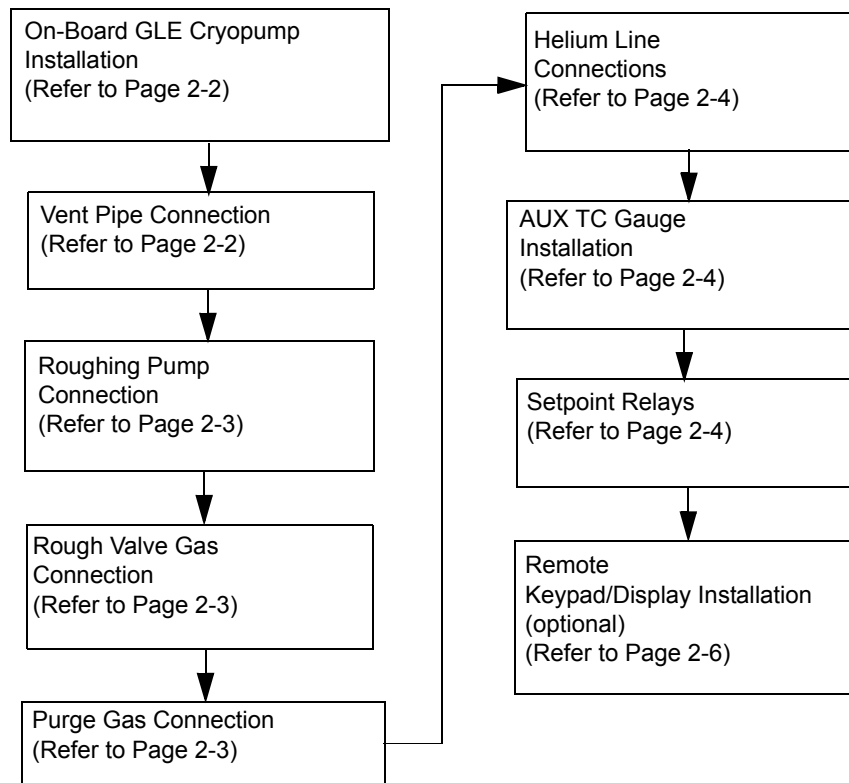

Figure 2-1: Block Diagram for On-Board GLE Cryopump Installation

On-Board GLE Cryopump Installation

The On-Board GLE Cryopump may be installed in any orientation without affecting its performance.

Before mounting the On-Board GLE Cryopump to the vacuum system, a high-vacuum isolation valve (Hi-Vac valve) should be installed between the On-Board GLE Cryopump and the vacuum chamber to isolate the On-Board GLE Cryopump from the chamber during rough pumping, cooldown, and regeneration.

Install the On-Board GLE Cryopump on the vacuum system as follows:

1. Remove the protective cover from the main flange of the On-Board GLE Cryopump.
2. Clean all sealing surfaces and install the O-ring or metal seal gasket as appropriate.
3. Mount the On-Board GLE Cryopump to the Hi-Vac valve or vacuum chamber mounting flange. Be sure all mounting bolts are secure.

Vent Pipe Connection

The On-Board GLE Cryopump pressure relief valve can be vented directly into the room or can be connected to an exhaust system.

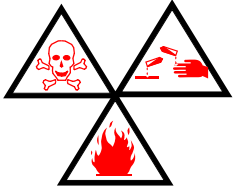
	WARNING
If toxic, corrosive, or flammable gases are pumped, a vent pipe must be connected to the On-Board GLE Cryopump relief valve and directed to a safe location.	

When connecting a vent pipe to your On-Board GLE Cryopump, the 1.30-inch diameter x 1.38-inch long volume around the relief valve must remain open for proper relief valve operation.

NOTE: A Relief Valve Adapter Exhaust Kit (CTI- CRYOGENICS P/N 8080250K008) is available. Refer to **Appendix A** and call you local customer support center for more information.

The enhanced On-Board 8F Cryopump installation kit includes a 6 foot (11.83 m) length of 1/2 inch ID (12.7 mm) poly tube with associated fittings to allow venting of the cold exhaust as desired in cases where a hard plumbed manifold is not used.



CAUTION

For the enhanced On-Board 8F Cryopump, if an exhaust manifold is used, it must have a minimum ID of a 1/2 inch ID (12.7 mm).

Roughing Pump Connection

NOTE: The roughing system must provide 10 cfm (measured at atmosphere and at each On-Board GLE Cryopump) to successfully utilize On-Board FastRegen capability.

Connect your On-Board GLE Cryopump to a roughing pump system using a roughing line with the largest inside diameter possible to minimize the roughing time required during start-up procedures prior to normal operation. The roughing pump should have a blank-off pressure of less than 20 microns.

The roughing pump connects to the On-Board GLE Cryopump roughing valve as shown in [Figure 1-6](#) or [Figure 1-7](#). The valve will accept an ISO NW-25 flange.

1. Install the roughing pump line to the On-Board GLE Cryopump roughing valve port using the clamp provided. Tighten the clamp securely.

Rough Valve Gas Connection

Attach the gas supply line from a 60-80 psig gas supply to the 1/8 NPTF roughing valve fitting. Make sure to attach the gas supply line to the valve fitting that has a filter screen at the attachment connection.

Purge Gas Connection

Connect your purge gas supply line to the purge valve 1/8 NPTF fitting. Adjust the supply pressure to 10 - 25 psig or 40 - 80 psig, depending upon the label on the purge valve, yielding 1-2 cfm.

Helium Line Connections

Make the connections between the On-Board GLE Cryopump and compressor. Refer to [Figure 1-6](#) or [Figure 1-7](#) while making the component interconnections.

1. Remove all dust plugs and caps from the supply and return lines, compressor, and On-Board GLE Cryopump. Check all fittings.
2. Connect the helium-return line from the gas-return connector on the rear of the compressor to the gas-return connector on the On-Board GLE Cryopump.
3. Connect the helium supply line from the supply connector on the cartridge to the gas-supply connector on the On-Board GLE Cryopump.
4. Attach the supply and return line identification decals (CTI-CRYOGENICS supplied) to their respective connectors.

Verify proper helium supply static pressure as described in the Installation Section of the appropriate Compressor Manual.

Auxiliary (AUX) TC Gauge Installation

You may purchase an auxiliary TC gauge tube, P/N 8112096 and an auxiliary TC gauge cable assembly, P/N 8112098G001.

When used, the auxiliary TC gauge is an extra gauge that can be installed on the User's equipment to read vacuum between 1 and 1000 microns. It comes with a 1/8 NPT pipe thread. Screw the TC tube into a 1/8 NPT fitting. Attach the auxiliary TC cable to the tube and to the connector on the On-Board module. Refer to [Figure 2-2](#).

NOTE: It may be necessary to zero the auxiliary TC gauge. Refer to the appropriate **On-Board Module Programming and Operation Instructions** for more information.

Setpoint Relays

When the setpoint relays are used, connection to the relays (R1 and R2) is made via the Relays connector located on the On-Board Module. If your On-Board GLE Cryopump configuration requires use of the setpoint

relays, refer to [Figure 2-2](#) and proceed as follows:

The setpoint relays are two mechanical relays that are incorporated into the On-Board GLE Cryopump for the User's application. The relays are rated at 1 amp at 25V AC/DC. The relays have both normally-open and normally-closed contacts. Connection to the relays are made through the 9-pin D connector labeled Relays on the connector plate on the On-Board GLE Cryopump. Refer to [Figure 2-2](#) for pin identification.

Refer to the appropriate **On-Board Module Programming and Operation Instructions** for instructions on programming the setpoint relays.

1. Determine whether your On-Board equipment requires setpoint relay contacts to be either in a normally-open or normally-closed position for your application.
2. Referring to [Figure 2-2](#), prepare a 9-pin DSub mating connector, meeting MIL DTL 24308/1-1 and equipment requirements.
3. Upon completion, connect the setpoint relay cable to the **RELAYS** connector on the On-Board Module.
4. Program the relays as described in the appropriate **On-Board Module Programming and Operation** manual.

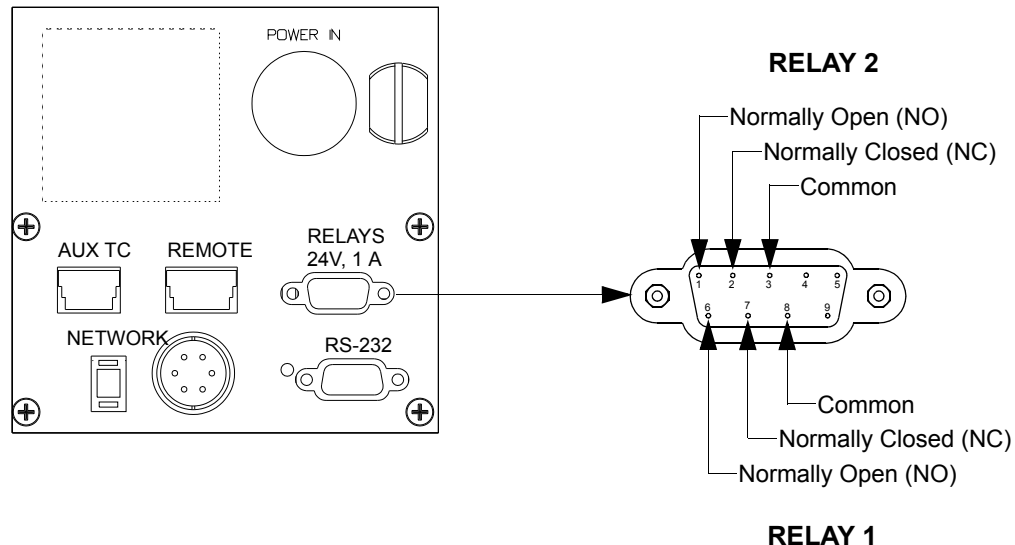

Figure 2-2: Setpoint Relays Connector Pin Identification

Remote Keypad/Display Installation (Optional)

When used, the remote keypad/display is a 19-inch rack-mountable unit. Mount the unit to a rack and then connect it to the REMOTE connector on the On-Board GLE Cryopump Module using the cable supplied with the remote keypad.

The On-Board GLE Cryopump can be operated both from the remote and from the attached keypad/display.



CAUTION

When installing remote keypad cable, care should be taken to route the cable away from power cables and any equipment that may generate excessive EMI conditions.

Section 3 - Troubleshooting

Introduction

The primary indication of trouble in a vacuum pumping system is a rise in base pressure of your vacuum chamber. A rise in the base pressure may be caused by a leak in the vacuum system, a fault in the On-Board GLE Cryopump, or by saturation of the 15K cryo-adsorbing charcoal array within the On-Board GLE Cryopump (regeneration may be necessary). If the On-Board GLE Cryopump temperature is below 20K it should pump at rated capacity; a high base pressure is usually caused by an air-to-vacuum leak in the system.

If you suspect a leak in your vacuum system, isolate the On-Board GLE Cryopump by closing the Hi-Vac valve and leak check your vacuum chamber. If no leaks are found, a leak may be present below the Hi-Vac valve (cryopump). Leak checking below the Hi-Vac valve should be performed with the On-Board GLE Cryopump shut off and at room temperature. Leak checking while the On-Board GLE Cryopump is operating may mask leaks that are present (due to the ability of the cryopump to pump helium). If no leak is found, refer to the cryopump troubleshooting procedures summarized in [Table 3-1](#).

The problems presented in [Table 3-1](#) are followed by possible causes and corrective actions. The causes and corresponding actions are listed in their order of probability of occurrence.

Maintaining a log of certain parameters during normal operation can be a valuable tool in troubleshooting the cryopump. The log may contain many parameters, however, the following minimum parameters should be included: the cooldown time to 20K, the roughing time to 50 μ , the time to base pressure at crossover, the time between regeneration cycles, and the compressor pressure reading.

Technical Inquiries

Please refer to **Appendix A** of this manual for a complete list of the CTI-CRYOGENICS world wide customer support centers.

Table 3-1: Cryopump Troubleshooting Procedures

Problem	Possible Cause	Corrective Action
High base pressure of vacuum system, and a cryopump temperature <i>below</i> 20K.	Air-to-vacuum leak in vacuum system or in cryopump.	Check cryopump relief valve for proper seating. Check cryopump for leaks. Check vacuum chamber and Hi-Vac valve for leaks.
	High partial pressure of non-condensables (helium, hydrogen, or neon) within the cryopump because the 15K array has reached full capacity.	Regenerate the cryopump as described in the appropriate On-Board Module Programming and Operation Instructions .
	One of the arrays is loose, thereby preventing good thermal contact with its cold station on the cold head.	Warm the cryopump to ambient temperature, and retighten the arrays to 15-20 inch/pounds.
High base pressure of vacuum system, and a cryopump temperature <i>above</i> 20K.	Decrease in cryopump cold head performance.	If the helium return pressure gauge reads below the normal operating return pressure 100-120 psig (690-827 kPa), add gas as described in the 9600 Compressor Manual .
	High partial pressure of non-condensables (helium, hydrogen, or neon) within the cryopump because the 15K array has reached full capacity.	Regenerate the cryopump as described in the appropriate On-Board Module Programming and Operation Instructions .
	Excessive thermal load on frontal array.	Reduce the thermal radiation load by 1) shielding the cryopump or 2) lowering the temperature of the radiating surface.

Table 3-1: Troubleshooting Procedures (continued)

Problem	Possible Cause	Corrective Action
Cryopump fails to cool down to the required operating temperature or takes too long to reach that temperature (20K).	Low helium supply pressure.	Add gas as described in the 9600 Compressor Manual .
	Compressor problems.	Refer to the 9600 Compressor Manual .
	Leak in vacuum system or cryopump.	Check the cryopump relief valve for proper seating. Check cryopump for leaks. Check vacuum system for leaks.
	Incomplete regeneration may not have fully cleaned the adsorbing array. Partial pressures of non-condensables (hydrogen, neon or helium) may remain.	Regenerate the cryopump as described in the appropriate On-Board Module Programming and Operation Instructions .
No display.	No power to On-Board GLE Cryopump.	Check electrical connections; be sure the power switch at the compressor controller is turned on. Check fuses. If power is turned on, try turning it off and on to reboot the electronics. Change electronics module.
Display does not update, and/or keys do not function.	Electronics has locked up.	Try to reboot the system by turning the On-Board power switch located at the compressor controller off and on. Replace the On-Board electronic module.
Rough valve clicks but does not open and close.	Too little or no air pressure to drive valve.	Increase air pressure to 60 psig minimum, 80 psig maximum.

This Page Left Intentionally Blank

Section 4 - Maintenance

Helium Circuit Decontamination

The information in this section guides you through removing gaseous contamination from an On-Board GLE Cryopump helium circuit by freezing the contaminant in the coldhead of the On-Board GLE Cryopump. A contaminated helium circuit will cause the On-Board GLE Cryopump to operate in a noisy manner, typically referred to as *ratcheting*, which degrades On-Board GLE Cryopump performance.

Separate decontamination of the compressor is only required if the compressor has been opened to atmosphere or the helium pressure in the compressor has dropped to zero.

Three methods of decontamination are described in [Table 4-1](#) and on the following pages. These methods all have isolating gaseous contamination in common by freezing them in one or more cold On-Board GLE Cryopumps. The method to be used will most likely be determined by the amount of time available for the decontamination.

Table 4-1: Methods of Decontamination

Method	Starting Condition	Estimated Time	Effectiveness of Decontamination
1. Cooldown and Sequential decontamination of all On-Board Cryopumps	Requires all On-Board GLE Cryopumps to be cold.	After all On-Board GLE Cryopumps are cold, 45 minutes to decontaminate the first On-Board GLE Cryopump. 30 minutes for each additional On-Board GLE Cryopump.	Maximum
2. Decontamination of only cold On-Board Cryopumps	Only one On-Board GLE Cryopump needs to be cold.	45 minutes to decontaminate the first <i>cold</i> On-Board GLE Cryopump. 30 minutes for each additional <i>cold</i> On-Board GLE Cryopump.	Acceptable

Table 4-1: Methods of Decontamination

Method	Starting Condition	Estimated Time	Effectiveness of Decontamination
3. Simultaneous decontamination of all On-Board Cryopumps using helium manifold	Only one On-Board GLE Cryopump needs to be cold.	45 minutes	Acceptable (may need to be repeated in several months).

NOTE: *If the On-Board GLE Cryopump does not reach its normal operating temperature (below 20K), then that performance degradation may be caused by any of the following:*

- a. Helium gas contamination
- b. Poor vacuum
- c. Thermal load on the On-Board GLE Cryopump arrays

Performing a Fast or Full regeneration cycle will *not* remove gaseous contamination from an On-Board helium circuit. Unless the decontamination procedure is performed, the noisy On-Board GLE Cryopump condition will repeat itself within one - four weeks.

Background

The On-Board GLE Cryopump contains a cryogenic refrigerator assembly called a *coldhead*. There is no way to visually inspect the internal components, so it is best to detect problems by listening for unusual sounds. If the coldhead runs quietly at start up, but begins to make a *ratcheting* noise after the On-Board GLE Cryopump is cooled down, then contaminated helium is the most probable cause.

All gases other than helium can freeze in the coldhead. During manufacturing of On-Board GLE Cryopump systems, gaseous impurities are removed using stringent manufacturing control. The delivered system contains sufficiently low concentrations of gaseous impurities so they are not of concern.

It is possible, over long periods of operation, that additional gaseous contaminants can be released. These gases, along with any air that is added accidentally during installation, will collect in the coldhead as frozen gas. The frozen gas may partially block the regenerator which increases the amount of torque required to drive the displacer mechanism to the point that the motor noise (ie: *ratcheting*) may increase and result in coldhead motor stalling.

These gaseous contaminants can be removed by first freezing them in the coldhead, then disconnecting the helium supply and return lines, warming the coldhead followed by de-pressurizing and pressurizing the helium gas in the coldhead to remove them. The use of this decontamination procedure will return most On-Board GLE Cryopumps to proper operation without the need for removal of the On-Board GLE Cryopump from the tool.

NOTE: *It is strongly recommended that this procedure be performed as soon as possible after the ratcheting noise appears to minimize mechanical loading on the On-Board GLE Cryopump drive mechanism.*

NOTE: *If any additional help is needed, refer to **Appendix A** in this manual for the location of the nearest CTI-CRYOGENICS Customer Support Center.*

Equipment/Tools Requirements

The following tools and equipment must be available to perform this decontamination procedure. If you do not have this equipment, refer to **Appendix A** and call your local Customer Support Center to order the equipment needed.

Table 4-2: Decontamination Tools and Equipment

CTI-CRYOGENICS Part Number	Description	Quantity
8080250K003	Maintenance Manifold Kit	1
7021002P001	Charging Hose	1
8043079G060	5 Ft. Flexlines (or longer)	2
-	Ultra Pure Helium (99.999%)	-
571716	1.0 Inch Self Sealing Coupling Wrench	1
571717	1 1/8 Inch Self Sealing Coupling Wrench	1
571718	1 3/16 Inch Self Sealing Coupling Wrench	1
8080015K001	Keypad/display	1
8031403	0-400/0-3000 psig Regulator	1

NOTE: *For best results, CTI-CRYOGENICS suggests the use of a dedicated helium bottle, which regulator and charge line which are never separated.*

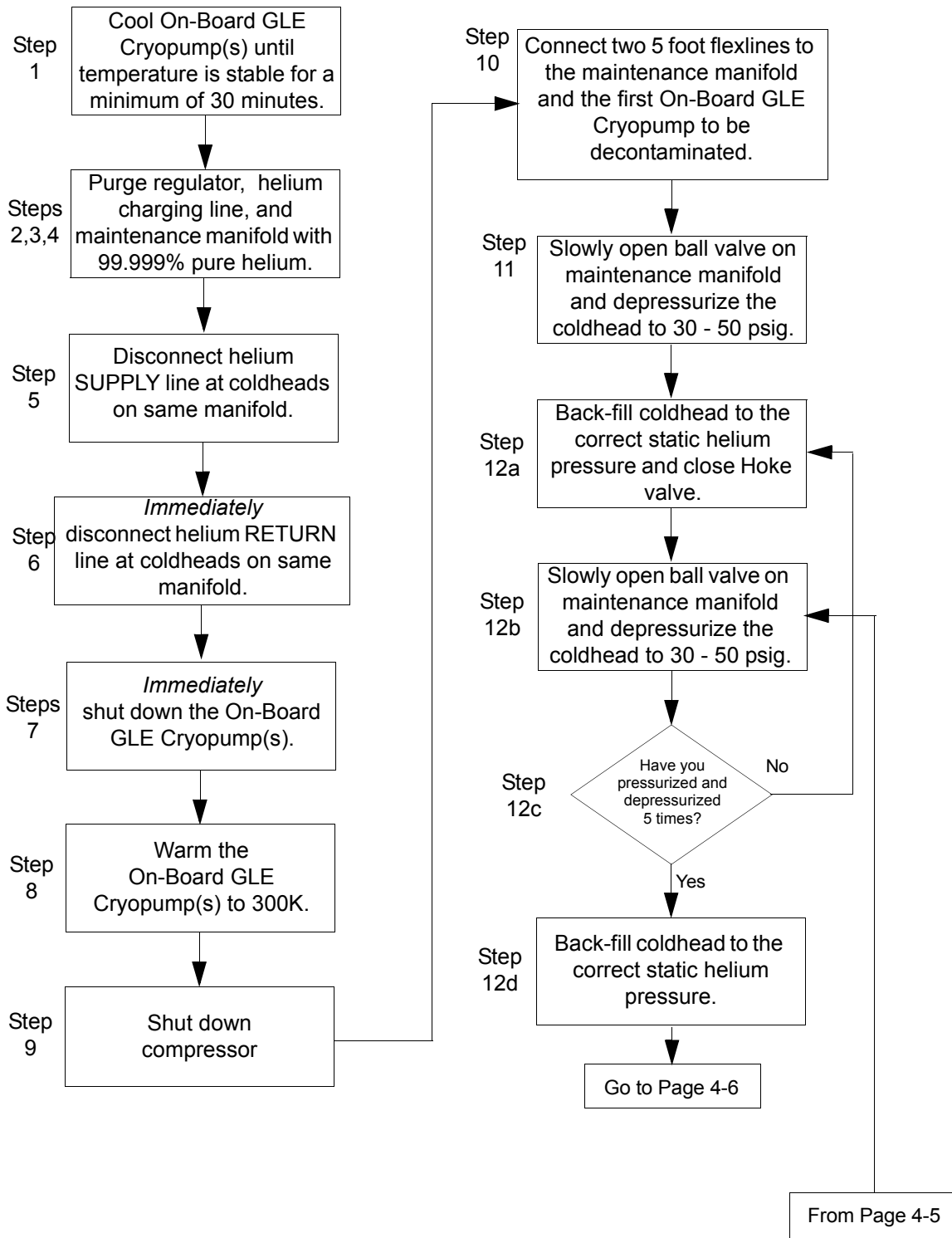

Figure 4-1: Decontamination Flowchart

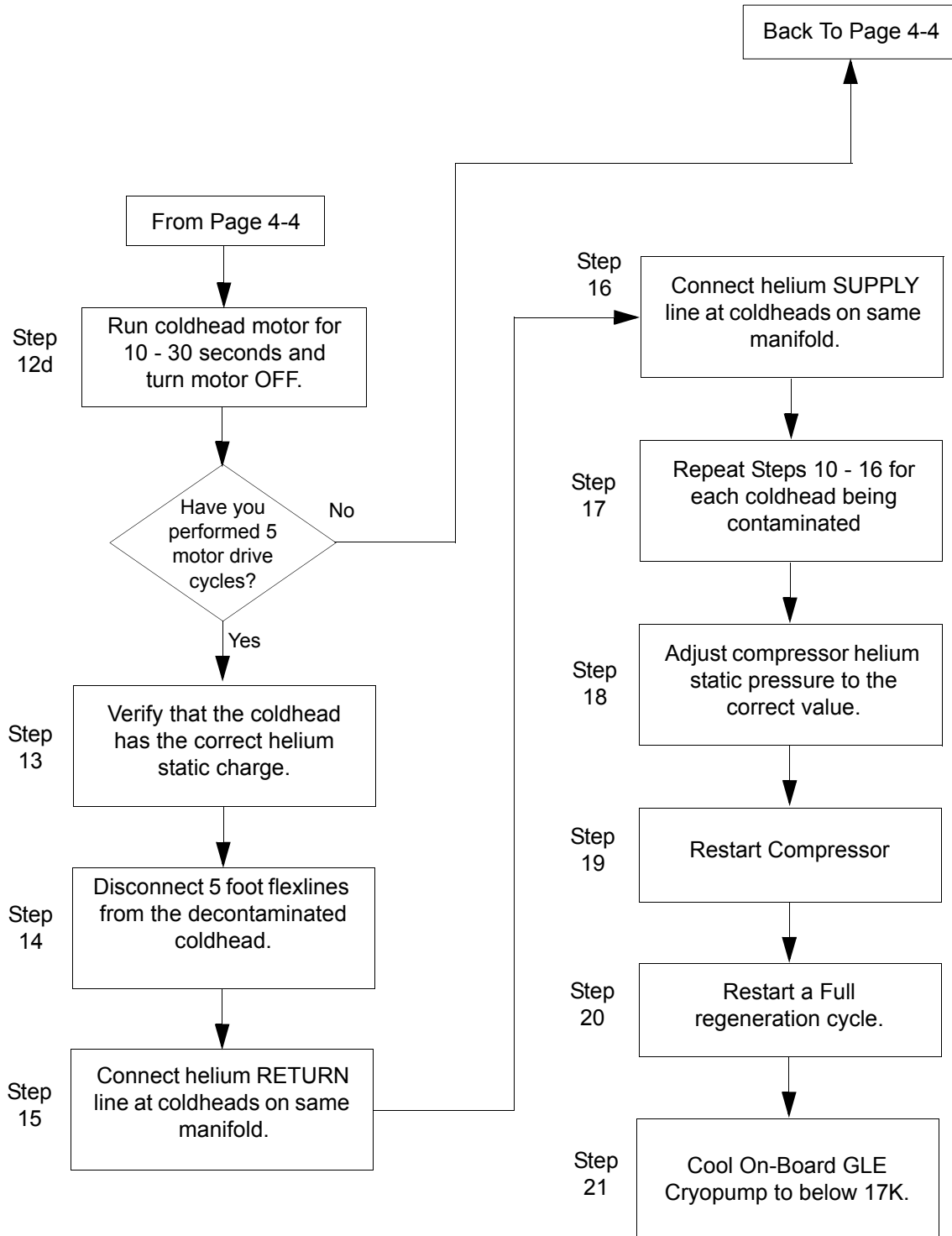

Figure 4-1: Decontamination Flowchart (continued)

Method 1 - Decontaminate all On-Board GLE Cryopumps

This procedure removes gaseous contamination from the helium circuit by cooling each On-Board GLE Cryopump so the gaseous contamination is frozen in the coldhead. Each On-Board GLE Cryopump is then decontaminated in sequence. This procedure is outlined in [Figure 4-1](#).

High helium gas pressure may be present within high vacuum pump systems and can cause severe injury from propelled particles or parts.

1. All On-Board GLE Cryopumps on the same manifold should have been running with second stage below 25K for at least 30 minutes. If not, then cool the remaining On-Board GLE Cryopumps down and run for 30 minutes minimum after reaching 25K to trap contaminants in the coldhead. Continue with Step 2 even if any pump does not cool below 25K (its performance may already be affected by contamination). Close the high vacuum valves to isolate the On-Board GLE Cryopumps from the vacuum chamber.

After Step 1 has been completed, all of the coldheads have been cooled and the contaminant gases frozen in the coldhead.

2. Attach a regulator (0-400/0-3000 psig) and charging line to a helium bottle (99.999% pure). DO NOT OPEN THE BOTTLE VALVE AT THIS TIME.
3. Purge the regulator and charging line as described in Steps a through d below. Use only 99.999% helium gas.
 - a. Open the regulator a small amount by turning the adjusting knob clockwise until it contacts the diaphragm, turn the adjusting knob so that the regulator is barely open.
 - b. Slowly open the bottle valve, and purge the regulator and line for 10 to 15 seconds. Keep the helium flowing to prevent re-contamination.
 - c. Loosely connect the charge line to the closed Hoke valve on the maintenance manifold. Refer to [Figure 4-3](#).
 - d. Continue to purge the charge line for 30 seconds, and tighten the charge line flare fitting onto the Hoke valve while the helium is flowing.

4. Open the ball valve using the extended handle. Open the Hoke valve. Purge the manifold for 30 seconds, close the ball valve, then close the Hoke valve.

Steps 2 - 4 are required to ensure that the regulator, charging line and the maintenance manifold will be purged of air and that the air trapped in the regulator will not diffuse back into the helium bottle. For best results,

CTI-CRYOGENICS suggests the use of a dedicated helium bottle, regulator and charge line which are never separated.

Once Step 4 has been completed, all of the coldheads have been cooled and the gaseous contaminant frozen in the coldhead. The maintenance manifold has also been connected to the helium bottle and filled with clean helium.

NOTE: *The helium SUPPLY line should be disconnected first to prevent the crosshead relief valve from opening.*

5. While each On-Board GLE Cryopump is still operating, disconnect the helium SUPPLY line at all of the coldheads on the same manifold. The On-Board GLE Cryopump helium supply line is shown in [Figure 4-2](#).



CAUTION

Be sure to use two wrenches to ensure that the self sealing coupling adapter does not back out during disassembly. Disconnect the helium supply line. Refer to [Figure 4-4](#).

6. Immediately after Step 5, and while each On-Board GLE Cryopump is still operating, disconnect the helium RETURN line at all of the coldheads on the same manifold. The On-Board GLE Cryopump helium return line is shown in [Figure](#) .

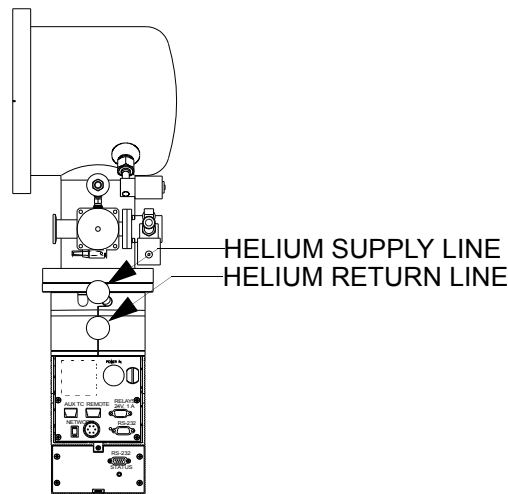

Figure 4-2: On-Board GLE Cryopump Helium Supply and Return Lines

7. Immediately after Step 7, shut down all of the On-Board GLE Cryopumps as described in the appropriate **On-Board Module Programming and Operation Instructions** manual.
8. Warm the On-Board GLE Cryopumps to 300K as follows:
 - a. Regenerate each On-Board GLE Cryopump to be decontaminated by pressing the REGEN button, followed by 1 then 2 on the Network Terminal keypad.
 - b. When the pumps reach 300K, discontinue the regeneration cycle by pressing REGEN and 0. Repeat this process on each pump.

After Step 8 has been completed, all of the coldheads have been cooled and the contaminant gases frozen in the coldhead. Helium gas lines have been disconnected at the coldheads, and the coldheads warmed up to 300K. The next step is to remove the contaminant from each coldhead in sequence.

9. Shut down the compressor.
10. Connect the two helium flexlines to the maintenance manifold and the coldhead of the first On-Board GLE Cryopump to be

decontaminated.



CAUTION

Be sure to use two wrenches to ensure that the self sealing coupling adapter does not back out during disassembly. Disconnect the helium supply line. Refer to [Figure 4-4](#).

11. De-pressurize the coldhead to between 30 and 50 psig (200 and 330 kPa) by slowly opening the ball valve and allowing the helium to bleed out slowly.



CAUTION

Reducing the coldhead pressure below 30 psig (200 kPa) may introduce more contaminants into the helium circuit.

12. Perform the following Steps in sequence:

NOTE: Refer to appropriate *Compressor Installation, Operation, and Maintenance Instructions* for the correct static helium charge pressure.

- a. Back-fill the coldhead with helium to the correct static charge pressure by adjusting the regulator to the required pressure, and opening the Hoke valve on the manifold. Close the Hoke valve when the pressure is correct.
- b. De-pressurize the coldhead to between 30 and 50 psig (200 and 330 kPa) by slowly opening the ball valve and allowing the helium to bleed out slowly. Do not reduce the pressure to less than 30 psig or the coldhead may be further contaminated.
- c. Perform the flushing Steps 12a and 12b four more times.
- d. Again back-fill the coldhead to the correct static charge pressure and run the coldhead drive motor for 10 to 30 seconds by using the remote keypad. Ensure the network cable is removed and press CONTROL and 1 to turn the motor on. Press 0 to turn the motor off.
- e. Repeat Steps b - d four times. There are a total of 5 drive motor runs with five flushes each for a total of 25 flushes.

NOTE: Refer to appropriate *Compressor Installation, Operation, and Maintenance Instructions* for the correct static helium charge pressure.

13. Verify that the coldhead has the correct helium static charge pressure.
14. Disconnect the 5 foot flexlines from the decontaminated coldhead supply and return connectors.
15. Reconnect the system helium RETURN line to the return connector on the coldhead as shown in [Figure 4-2](#).
16. Reconnect the system helium SUPPLY line to the supply connector on the coldhead as shown in [Figure 4-2](#).

Once Step 16 has been completed, the decontamination of the first On-Board GLE Cryopump is completed and charged to the correct pressure with clean helium. The remaining coldheads need to be decontaminated.

17. Repeat Steps 10 - 16 for each coldhead being decontaminated.
18. Once Step 17 has been completed, the On-Board GLE Cryopumps are ready to be cooled down. Adjust the compressor pressure to the correct charge pressure.

***NOTE:** Refer to the appropriate Compressor Installation, Operation, and Maintenance Instructions for the correct static helium charge pressure value and adjustment procedure.*

***NOTE:** The charging adapter can be inserted into any helium line at the tool to simplify the final adjustment of system pressure. It should be removed after final pressure adjustment.*

19. Restart the compressor.
20. Start a Full Regeneration cycle on all the On-Board GLE Cryopumps to prepare the vacuum side of the On-Board GLE Cryopump.
21. Allow the On-Board GLE Cryopumps cryopumps to cool to below 17K.

If *ratcheting* in the On-Board GLE Cryopump reappears, refer to **Appendix A** and call your nearest CTI-CRYOGENICS Customer Support Center for additional technical assistance.

Decontamination Alternatives

Method #1 Decontaminate All Cryopumps

The preceding procedure is the most effective method to remove gaseous contaminants from the helium circuit. All On-Board GLE Cryopumps were first cooled down and the contaminant frozen. Each On-Board GLE Cryopump was decontaminated in sequence.

All On-Board GLE Cryopumps that are cold must be decontaminated. If they are cold and not decontaminated, then gases frozen in these On-Board GLE Cryopumps will re-contaminate the helium gas when they are warmed up.

Method # 2 Decontamination of Only Cold Cryopumps

If time is critical, then an alternate method of decontamination, using Method 1 as a basis may be used. This procedure will also remove gaseous contaminant in the system.

If certain On-Board GLE Cryopumps are warm in Step 1 then they can remain at room temperature (i.e. over 290K). With the compressor on and cold On-Board GLE Cryopumps left on, run these “warm” On-Board GLE Cryopumps for 5 minutes. Running these “warm” On-Board GLE Cryopumps for a short time will move any concentrated contaminant out of these coldheads into the compressor. The contaminants will then be carried to the cold On-Board GLE Cryopumps where they will be frozen.

In this method, the following Steps replace the corresponding Steps in Method 1:

Step 1 - Method #2

Any On-Board GLE Cryopumps on the same manifold which are running should have been running below 25K for at least 30 minutes. Any pumps warmer than 290K should be kept warm. Continue with Step 2 even if any pump does not cool below 25K (its performance may already be affected by contamination). Close the high vacuum valves to isolate the On-Board GLE Cryopumps from the vacuum chamber.

Step 17 - Method #2

Repeat Steps 10 - 16 for each On-Board GLE Cryopump which is not above 290K.

Method # 3 Grouped Decontamination using Manifold

The time required to decontaminate each On-Board GLE Cryopump in Method #1 after it is cooled and warmed up is about 30 minutes. If time is not available to decontaminate each On-Board GLE Cryopump in sequence, then the alternate is to decontaminate all On-Board GLE Cryopumps together, i.e.: *Grouped Decontamination*. At least one of the On-Board GLE Cryopumps must be cold. The decontamination is performed from the compressor side of the common supply and return manifolds.

In this method the following Steps replace the previous Steps:

Step 5 - Method #3

While each On-Board GLE Cryopump is still operating, disconnect the helium SUPPLY line at the compressor side of the common supply manifold at the tool.

Step 6 - Method #3

While each On-Board GLE Cryopump is still operating, disconnect the helium RETURN line at the compressor side of the common supply manifold at the tool.

Step 10- Method #3

Verify that the compressor is off. Connect the two 5 foot helium flexlines to the maintenance manifold and the compressor side of the common supply and return manifold.

**CAUTION**

Be sure to use two wrenches to ensure that the self sealing coupling adapter does not back out during disassembly. Disconnect the helium supply line. Refer to [Figure 4-4](#).

Steps 11 - 16 - Method #3

All connections are to the manifold, not the individual coldheads. All coldhead drive motors are to be run for 10 to 30 seconds using the remote keypads per Step 12d. At the end of Step 16, all of the On-Board GLE

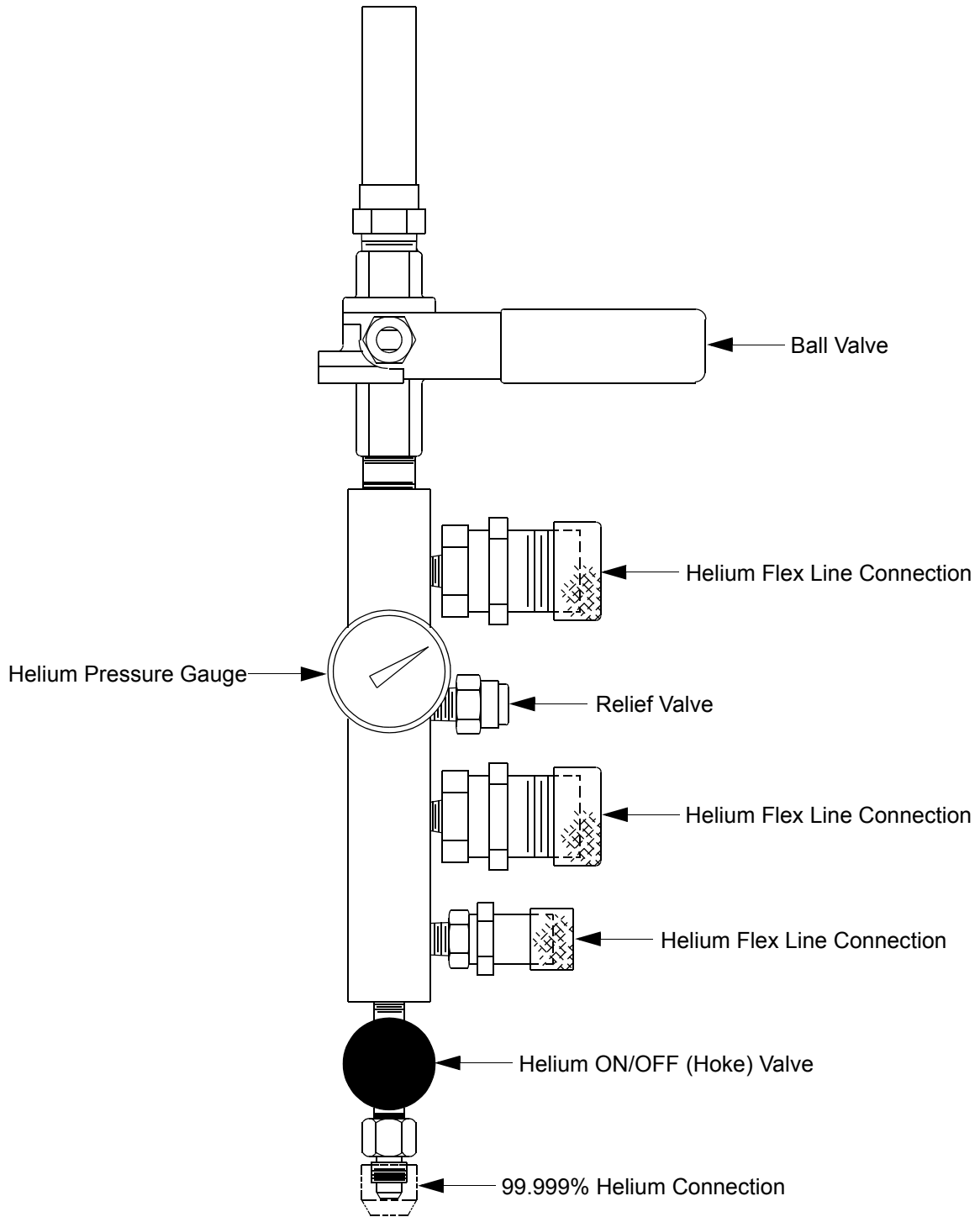

Cryopumps are decontaminated.

Figure 4-3: Maintenance Manifold Part Number 8032051G001

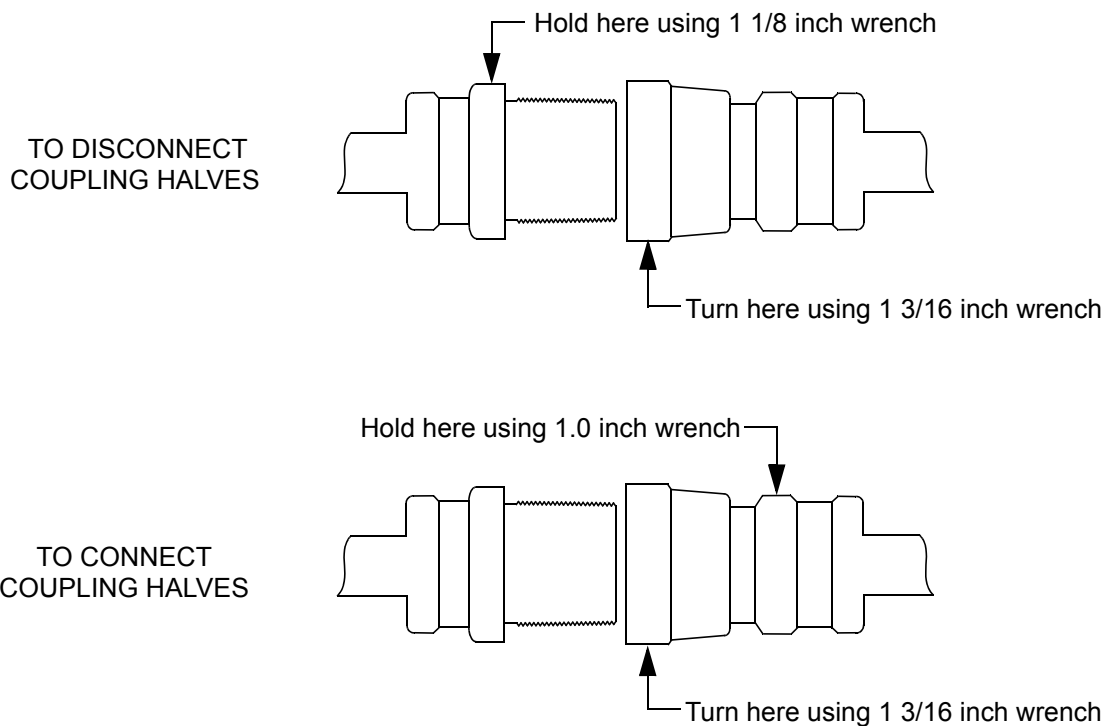

Figure 4-4: Proper Helium Line Coupling Disconnection/Connection

On-Board GLE Cryopump Cleaning



WARNING

If the On-Board GLE Cryopump has been used to pump toxic or dangerous materials, you must take adequate precautions to safeguard personnel.

Cleaning the arrays or other interior surfaces of the On-Board GLE Cryopump vacuum vessel is seldom required because dust buildup does not affect performance, and the special copper alloy cryo-condensing arrays are nickel plated for corrosion resistance.

If you wish to clean the arrays and other interior surfaces, follow the procedures below.

1. Confirm that an adequate supply of indium gasket material, P/N 7100001G006, is available to replace gaskets inadvertently

- damaged during disassembly.
2. Carefully disassemble the components in the vacuum vessel, including the arrays and radiation shield, to avoid damage to the indium gaskets.
 3. Clean the interior surface of the vacuum vessel, the 80K condensing array, and the 80K radiation shield as follows:
 - a. Wash each item in strong soap or detergent solution and hot water.
 - b. Rinse the items in *clean hot water*.
 - c. Air or oven dry all items at 150° F (66° C) maximum before reinstalling into the On-Board GLE Cryopump.



CAUTION

Do not clean the 15K cryo-adsorbing array, because you may severely contaminate the adsorbent in the cleaning process.

4. Wearing lint-free gloves, reassemble the On-Board GLE Cryopump. Replace any indium gasket damaged during disassembly.

This Page Left Intentionally Blank

Appendix A - Customer Support Information

Customer Support Center Locations

To locate a Customer Support Center near you, please visit our website www.helixtechnology.com on the world wide web and select *CONTACT* on the home page.

Guaranteed Up-Time Support (GUTS)

For 24 hour, 7 day per week Guaranteed Up-Time Support (GUTS) dial:

800-367-4887 - Inside the United States of America

508-337-5599 - Outside the United States of America

Product Information

Please have the following information available when calling so that we may assist you:

- Product Part Number
- Product Serial Number
- Product Application
- Specific Problem Area
- Hours of Operation
- Equipment Type
- Vacuum System Brand/Model/Date of Manufacture

E-mail

For your convenience, you may also e-mail us at:

techsupport@helixtechnology.com

This Page Left Intentionally Blank

Index

A

Arrays and vacuum vessels 1-10
Auxiliary (AUX) TC Gauge
installation 2-4

B

Brooks Automation
contact information Front-ii

C

Cold head 1-10
Compressor gas and oil flows 1-10
Controlling pump remotely 1-7

D

Decontaminating helium circuit 4-1
Decontamination process
alternatives 4-10
tools required 4-3

H

Helium circuit
decontaminating 4-1
Helium line connection 2-4
Helium lines
connecting 2-4

I

Installation 2-1

K

Keypad, remote
mounting 2-7

M

Maintenance 4-1
Microprocessor system 1-1

O

Oil flows and compressor gas 1-10
On-Board 8 GLE Cryopump

Installation, operation, and maintenance
1-1

specifications 1-8

On-Board GLE Cryopump

description 1-1

installation 2-1

maintenance 4-1

On-board vacuum network controller module
1-6

P

PCM 1-4

Power conditioning module 1-4

Purge gas connection 2-4

Purge gas supply line
connecting 2-4

R

Relays, setpoint
connecting 2-4

Remote control operation 1-7

Remote keypad
mounting 2-7

Rough valve gas connection 2-3

Roughing pump connection 2-3

S

Safety precautions S-1

Setpoint relays
connecting 2-4

Specifications 1-8

T

Theory of operation 1-9

Troubleshooting 3-1

V

vacuum network controller module 1-6

Vacuum vessel and arrays 1-10

Valve gas, rough
connection 2-3

Vent pipe connection 2-2

This Page Left Intentionally Blank