



# Frequency Converter Installation Instructions

Information provided within this document is subject to change without notice, and although believed to be accurate, Brooks Automation assumes no responsibility for any errors, omissions, or inaccuracies.

AcuLigner™, AquaTran™, Assure™, AutoTeach™, AXM™, Basic Blue™, BiSymmetrik™, CenterSmart™, Cool Solutions™, Crate to Operate™, e-RMA™, e-Spares™, FastRegen™, FIXLOAD™, FrogLeg™, Fusion™, InLigner™, In-Sight®, InCooler™, Interface™, Jet™, Jet Engine™, M2 Nano™, PASIV™, PowerPak™, PerformanceBlue™, PowerPak™, PowerTools™, QuadraFly™, Radius™, Razor™, Reliance™, Reliance ATR™, RetroEase™, SCARA™, SmartPM™, SPOTLevel™, Synetics™, The New Pathway to Productivity™, Time Optimal Trajectory™, Time Optimized Path™, TopCooler™, TopLigner™, Ultimate Blue™, AC-407™, Vacu-Tran™, and Vision™ are trademarks of Brooks Automation.

AcuTran®, AeroLoader®, AcuTrap®, Brooks®, Brooks Automation®, Conductron®, Convectron®, Cryodyne®, Cryotiger®, E-VOLUTION®, GOLDLink®, Granville-Phillips®, Guardian®, GUTS®, Hercules®, In-Sight®, Leap-frog®, MagnaTran®, MapTrak®, Marathon®, Marathon Express®, Micro-Ion®, MiniConvectron®, MultiTran®, On-Board®, Polycold®, Stabil-Ion®, TrueBlue®, TurboPlus®, We Deliver Productivity®, and Zaris® are registered trademarks of Brooks Automation.

All other trademarks are properties of their respective owners.

© Brooks Automation 2012, All Rights Reserved. The information included in this manual is Brooks Proprietary Information and is provided for the use of Brooks customers only and cannot be used for distribution, reproduction, or sale without the express written permission of Brooks Automation. This information may be incorporated into the user's documentation, however any changes made by the user to this information is the responsibility of the user.



**For Technical Support:**

Location	GUTS® Contact Number
North America	+1-800-FOR-GUTS (1-800-367-4887) +1-978-262-2900
Europe	+49-1804-CALL-GUTS (+49-1804-2255-4887)
Japan	+81-45-477-5980
China	+86-21-5131-7066
Taiwan	+886-3-5525225
Korea	+82-31-288-2500
Singapore	+65-6464-1481

Visit us online: [www.brooks.com](http://www.brooks.com)

May 23, 2012      Part Num 8040520 Revision AA  
Oct. 14, 2008    Part Num 8040520 Revision 103

This technology is subject to United States export Administration Regulations and authorized to the destination only; diversion contrary to U.S. law is prohibited.

Printed in the U.S.A.

---

# Contents

---

## Introduction

Purpose .....	1-1
Frequency Converter Applications .....	1-1
Specifications .....	1-1

## Safety

Introduction .....	2-1
Signal Word Descriptions .....	2-1
Safety Shape Descriptions .....	2-3
References .....	2-3

## Installation

Introduction .....	3-1
9600 Compressor with On-Board Cryopumps .....	3-1
9600 Compressor with Cryo-Torr Cryopumps .....	3-3
8200 Single Phase Compressor with an On-Board Cryopump .....	3-5
8510 Compressor with On-Board Cryopumps .....	3-13
8500 Compressor with Cryo-Torr Cryopumps .....	3-17
1020R Compressor with On-Board Cryopumps .....	3-19
1020R Compressor with Cryo-Torr Cryopumps .....	3-21

---

# Appendices

- Overview ..... 4-1
  - Appendix A: Customer Support Information ..... 4-2
  - Customer Support Center Locations. .... 4-2
  - Guaranteed Up-Time Support (GUTS<sup>®</sup>) ..... 4-2
  - Product Information ..... 4-2
  - E-mail. .... 4-2

---

# 1

# Introduction

---

## Purpose

The Frequency Converter, P/N 8043202G001 - G005, 8124106G001 - G005, and 8124114G001 - G005, allows CTI-CRYOGENICS' equipment to operate efficiently when connected to a supply voltage with a line frequency of 50Hz.

The Frequency Converter, shown in Figure 1-1, is designed for use with CTI-CRYOGENICS' 9600, 8200, 8510, 8500, and 1020R compressors, and On-Board and Cryo-Torr Cryopumps.

## Frequency Converter Applications

The Frequency Converter supports various configurations of CTI-CRYOGENICS' compressors and cryopumps. Refer to **Section 2 - Installation** for information on installing the Frequency Converter for your particular compressor and cryopump application.

## Specifications

*Table 1-1: Frequency Converter General Specifications*

Parameter	Value
Weight	50 lbs (22.67 kg)
Ambient Temperature	50 - 100° F (10 - 38° C)

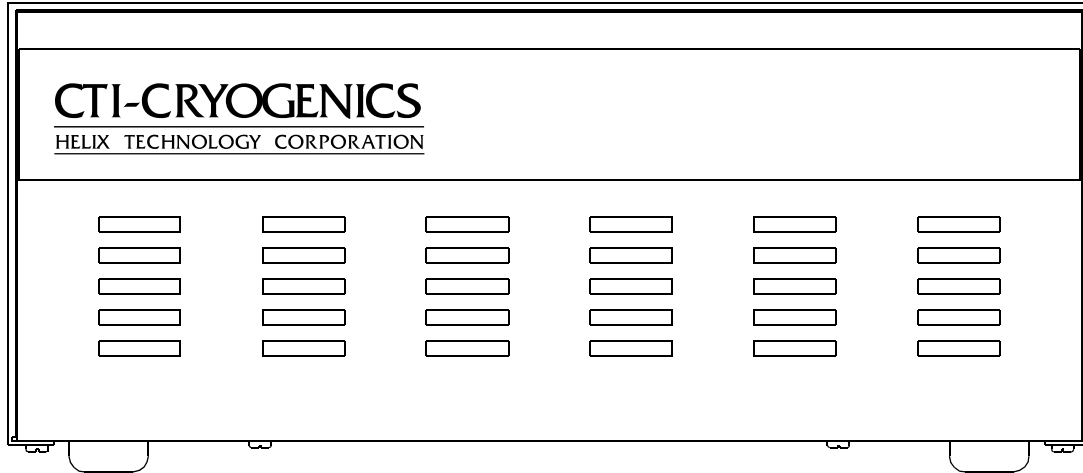

Front Panel View

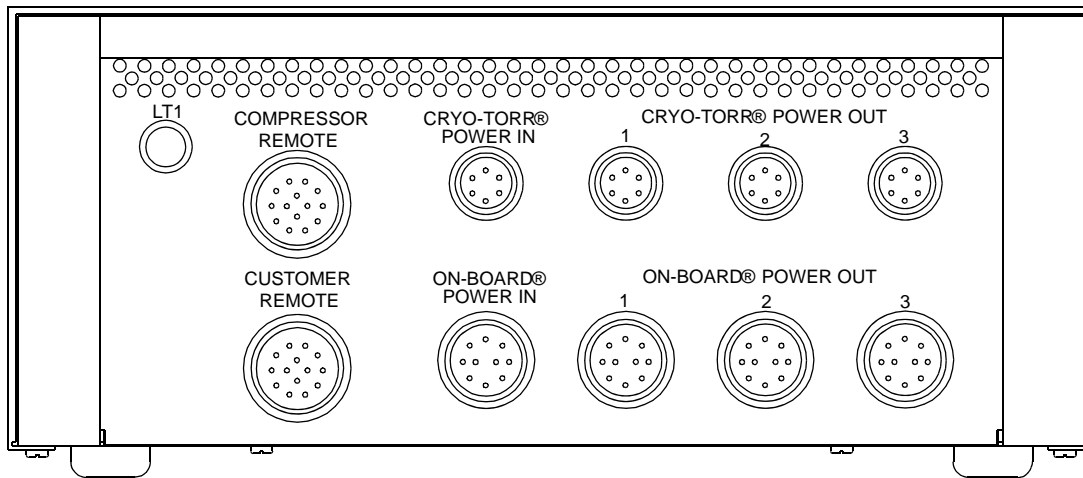

Rear Panel View

Figure 1-1: Frequency Converter Chassis Front and Rear Views

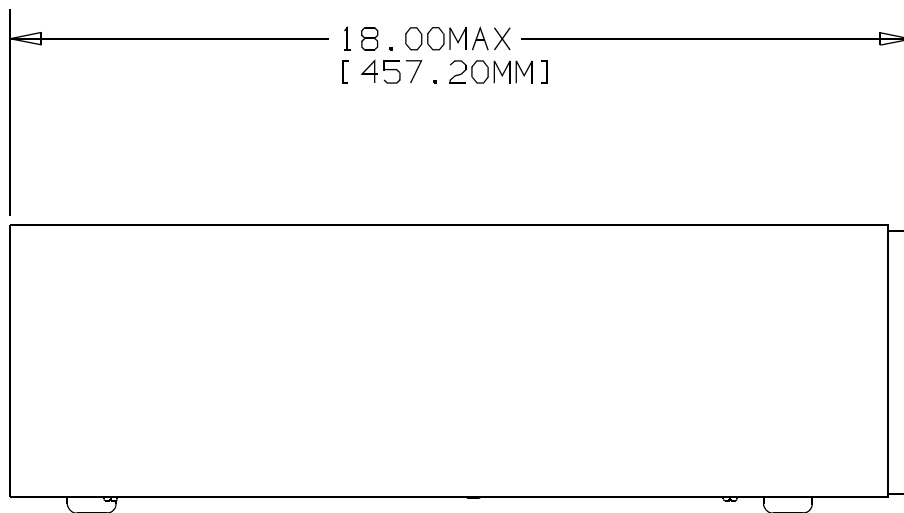
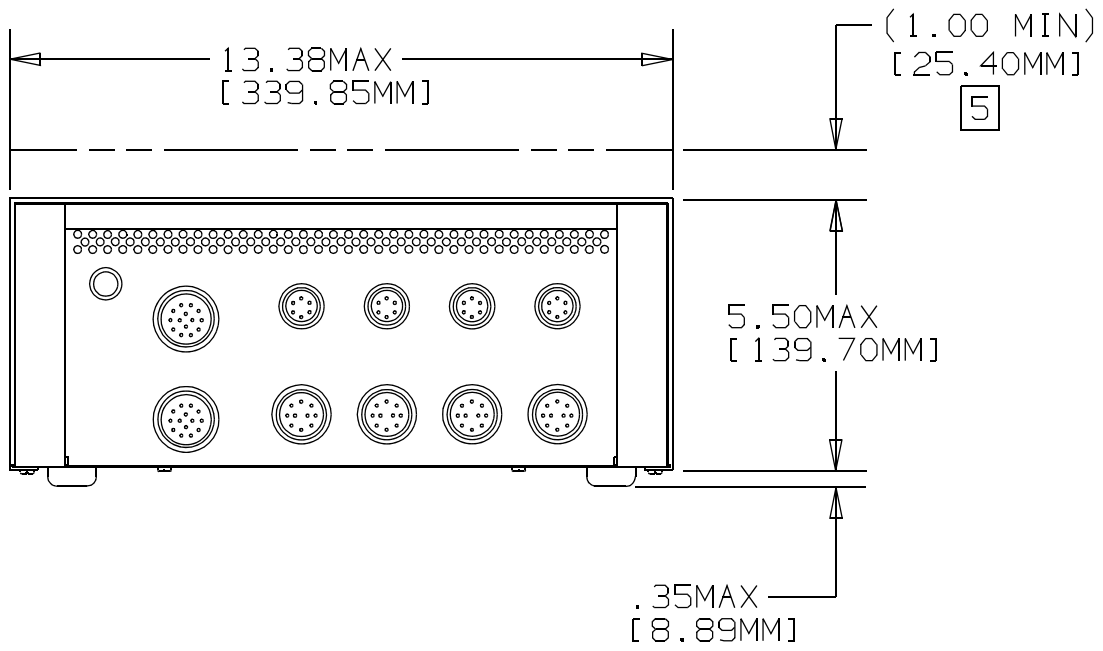

Figure 1-2: Frequency Converter Dimensions





## Overview

This chapter describes safety conventions for the Brooks Automation Product. All personnel involved in the operation or maintenance of the product must be familiar with the safety precautions outlined here.

**NOTE:** *These safety recommendations are basic guidelines. If the facility where the Product is installed has additional safety guidelines they should be followed as well, along with the applicable national and international safety codes.*

## Introduction

Follow all safety precautions during installation, normal operation, and when servicing CTI-Cryogenics products.



This chapter explains the safety conventions used throughout this manual. CTI-Cryogenics uses a specific format for cautions and warnings, which includes standard signal words and safety shapes.

See also the *Customer Support* appendix or call your local Customer Support Center for assistance.

## Signal Word Descriptions

All cautions and warnings contain signal words, which call attention to safety messages and designate the degree of hazard seriousness. The following table shows the signal words and their meanings that may be used in this document.

Table 2-1: Safety Signal Words



Term	Example	Definition
CAUTION		<p>A signal word that indicates a situation or unsafe practice, which if not avoided may result in <b>equipment damage</b>. A CAUTION is highlighted in yellow.</p>
CAUTION		<p>A signal word accompanied by a safety shape that indicates a potentially hazardous situation or unsafe practice. If not avoided, the action may result in <b>minor or moderate personal injury or equipment damage</b>. A CAUTION is highlighted in yellow.</p>
WARNING		<p>A signal word accompanied by a safety shape that indicates a potentially hazardous situation. If not avoided, the action may result in <b>serious injury or death</b>. A WARNING is highlighted in orange.</p>

---

## Safety Shape Descriptions

All cautions and warnings contain safety shapes, which have specific safety meanings. The following table shows some of the safety shapes used in this document and their meanings.

*Table 2-2: Safety Shapes*

<b>Example</b>	<b>Term</b>	<b>Shape Definition</b>
	General Warning	Indicates a general hazard. Details about this hazard appear in the safety notice explanation.
	High Voltage	Indicates a high voltage hazard.
	Hot Surface	Indicates a surface is hot enough to cause discomfort or a burn.

## References

For more information about safety standards, see the following documents:

- ISO 7010: 2003(E), Graphic symbols - Safety colours and safety signs - Safety signs used in workplaces and public areas
- ISO 3864-1: 2002(E), Graphic symbols - Safety colours and safety signs - Part 1: Design principles for safety signs in workplaces and public areas



## Introduction

This chapter provides all the information needed to connect the Frequency Converter to the 9600, 8200, 8510, 8500, and 1020R Compressors, which, in turn, are connected to On-Board or Cryo-Torr Cryopumps.

## 9600 Compressor with On-Board Cryopumps

This procedure involves the following components:

- 9600 Low-Voltage Compressor, CTI-CRYOGENICS P/N 8135900G001
- Frequency Converter, CTI-CRYOGENICS P/N 8043202G002, 8124106G002, or 8124114G002, which includes On-Board Power Cable, CTI-CRYOGENICS P/N 8112463G050
- On-Board Cryopumps

**NOTE:** *If installing a new 9600 Compressor along with the Frequency Converter, refer to the **9600 Compressor Installation, Operation, and Service Instructions** manual CTI-CRYOGENICS P/N 8040444.*

1. Carefully place the Frequency Converter on top of the 9600 Compressor as shown in Figure 2-1.
2. Connect the three On-Board power cables to the ON-BOARD POWER OUT outputs 1, 2 and 3 on the Frequency Converter.
3. Connect the On-Board Cryopump power cable, P/N 8112463G050 (supplied), between the ON-BOARD POWER IN, input on the Frequency Converter and the cryopump electrical outlet on the 9600 compressor.
4. Set the control circuit breaker on the rear panel of the 9600 compressor to the ON position.

**CAUTION**

Allow a 1.0 inch minimum space above the top of the Frequency Converter for adequate ventilation

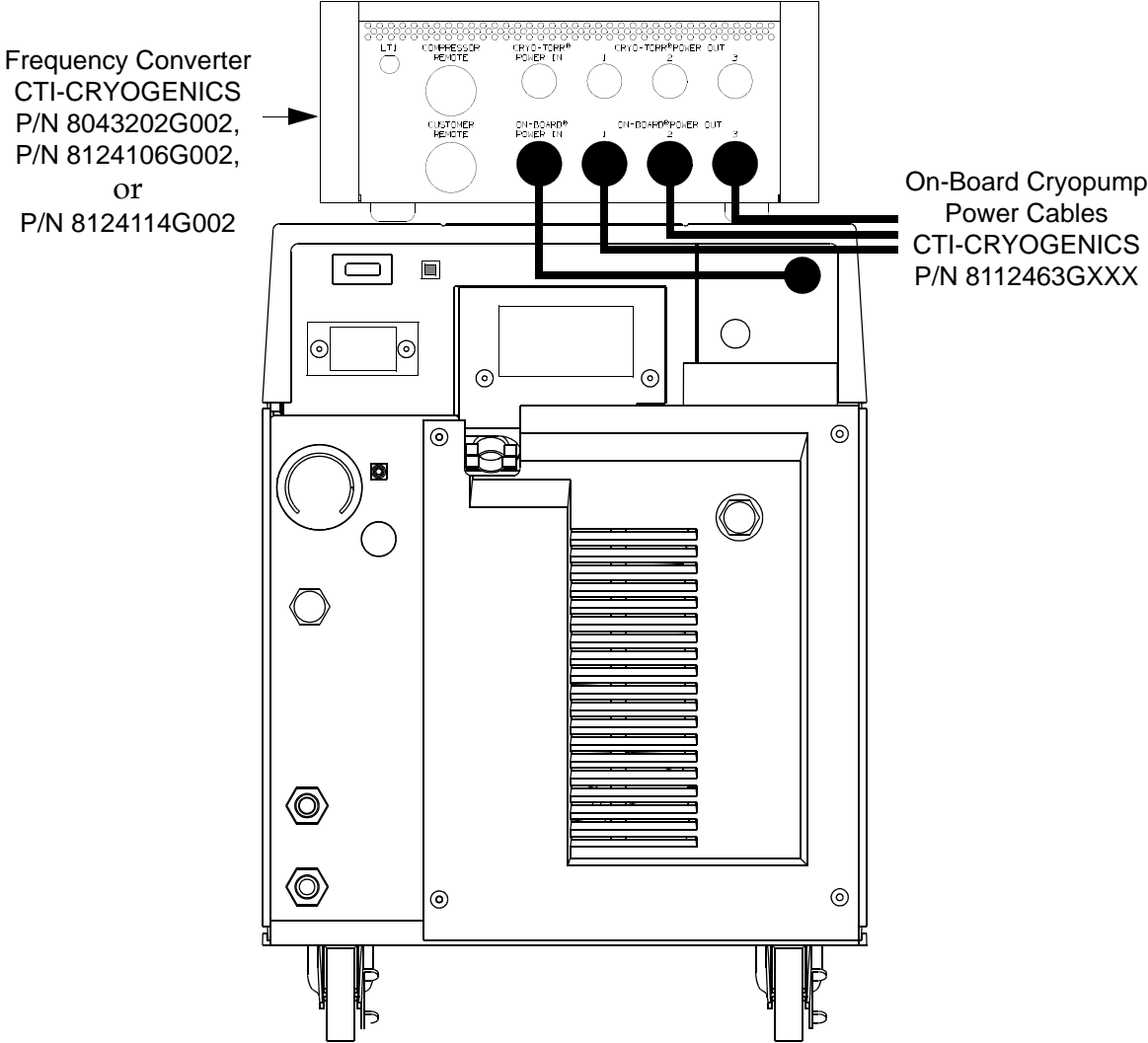

Figure 3-1: 9600 LV Compressor with On-Board Cryopumps

---

## 9600 Compressor with Cryo-Torr Cryopumps

This procedure involves the following components:

- 9600 Low-Voltage Compressor, CTI-CRYOGENICS P/N 8135900G001
- Frequency Converter, CTI-CRYOGENICS P/N 8043202G005, 8124106G005, or 8124114G005, which includes a cryopump power cable, CTI-CRYOGENICS P/N 8043209G050
- Cryo-Torr Cryopumps

**NOTE:** *If installing a new 9600 Compressor along with the Frequency Converter, refer to the **9600 Compressor Installation, Operation, and Service Instructions** manual CTI-CRYOGENICS P/N 8040444.*

1. Carefully place the Frequency Converter on top of the 9600 Compressor as shown in Figure 2-2.
2. Connect the three cryopump power cables to the CRYO-TORR POWER OUT outputs 1, 2 and 3 on the Frequency Converter.
3. Connect the cryopump power cable, P/N 8043209G050 (supplied), between the CRYO-TORR POWER IN, input on the Frequency Converter and the cryopump electrical outlet on the 9600 compressor.
4. Set the control circuit breaker on the rear panel of the 9600 compressor to the ON position.

**CAUTION**

Allow a 1.0 inch minimum space above the top of the Frequency Converter for adequate ventilation

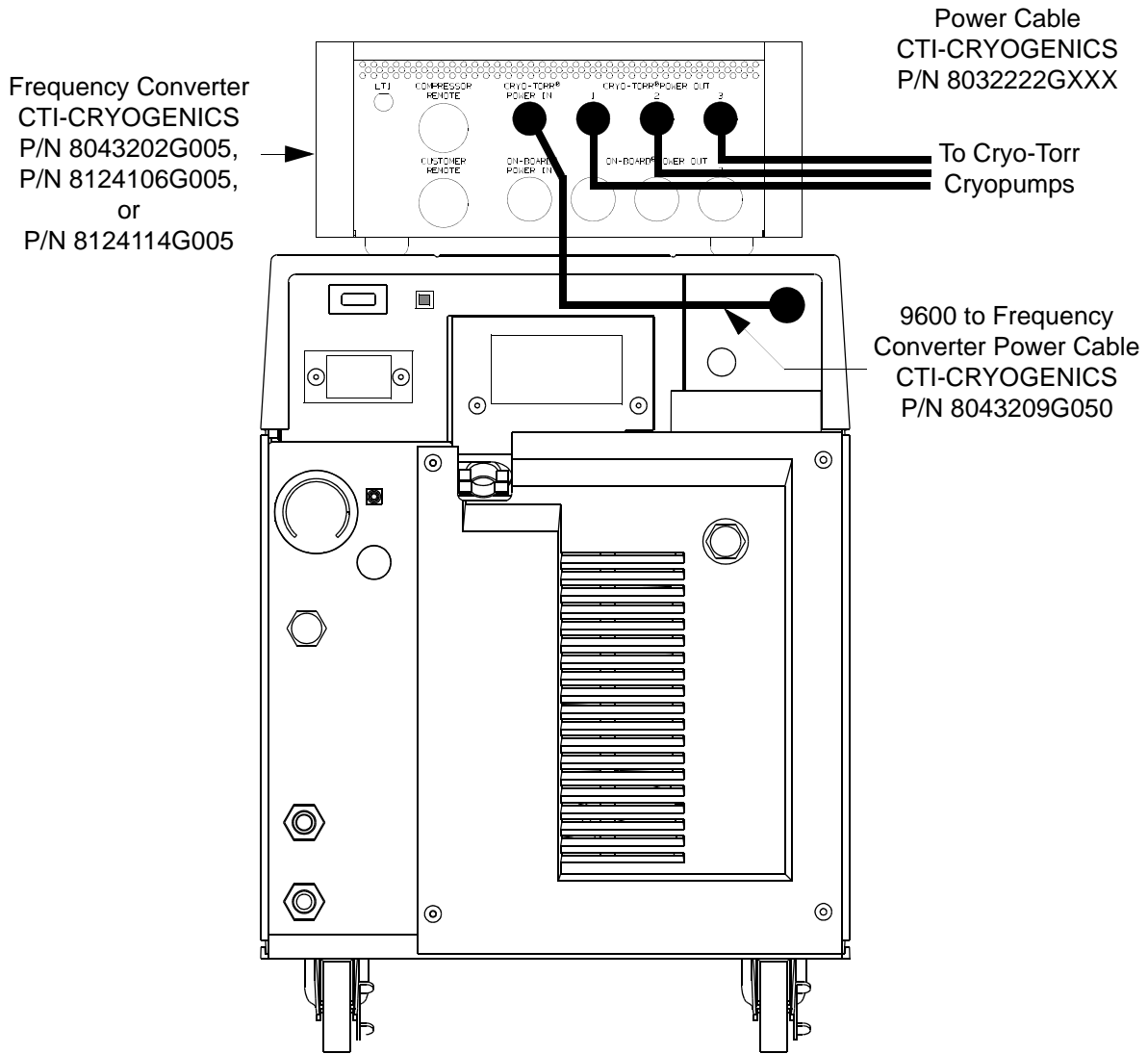

Figure 3-2: 9600 LV Compressor with an Cryo-Torr Cryopumps



---

## 8200 Single Phase Compressor with an On-Board Cryopump

This procedure involves the following components:

- 8200 Single Phase, Water or Air Cooled Compressor
- Frequency Converter, CTI-CRYOGENICS P/N 8043202G004, 8124106G004, or 8124114G004, which includes power cable CTI-CRYOGENICS P/N 8132646G050
- One On-Board Cryopump

**NOTE:** *If installing a new 8200 Compressor along with the Frequency Converter, refer to the **8200 Compressor Installation, Operation, and Service** manual CTI-CRYOGENICS P/N 8040353 for information on setting the control module to the proper operating voltage range before installing the Frequency Converter.*

1. Carefully place the Frequency Converter on top of the 8200 Compressor as shown in Figure 2-3.
2. Connect the On-Board Cryopump power cable CTI-CRYOGENICS P/N 8112463GXXX between one of the ON-BOARD POWER OUT connectors on the rear panel of the Frequency Converter and the POWER IN connector on the On-Board Cryopump Module.
3. Connect the power cable CTI-CRYOGENICS P/N 8132646G050 between the ON-BOARD POWER IN connector on the rear panel of the Frequency Converter and the ON-BOARD POWER connector on the rear panel of the 8200 compressor as shown in Figure 2-3.

**NOTE:** *Make sure the Frequency Selector Switch is set to the 60Hz position. Failure to do so will result in improper system operation.*

4. Set the Frequency Selector Switch on the front panel of the 8200 compressor to the 60Hz position.
5. Set the Power Switch on the front panel of the 8200 compressor to the ON position.

**CAUTION**

Allow a 1.0 inch minimum space above the top of the Frequency Converter for adequate ventilation

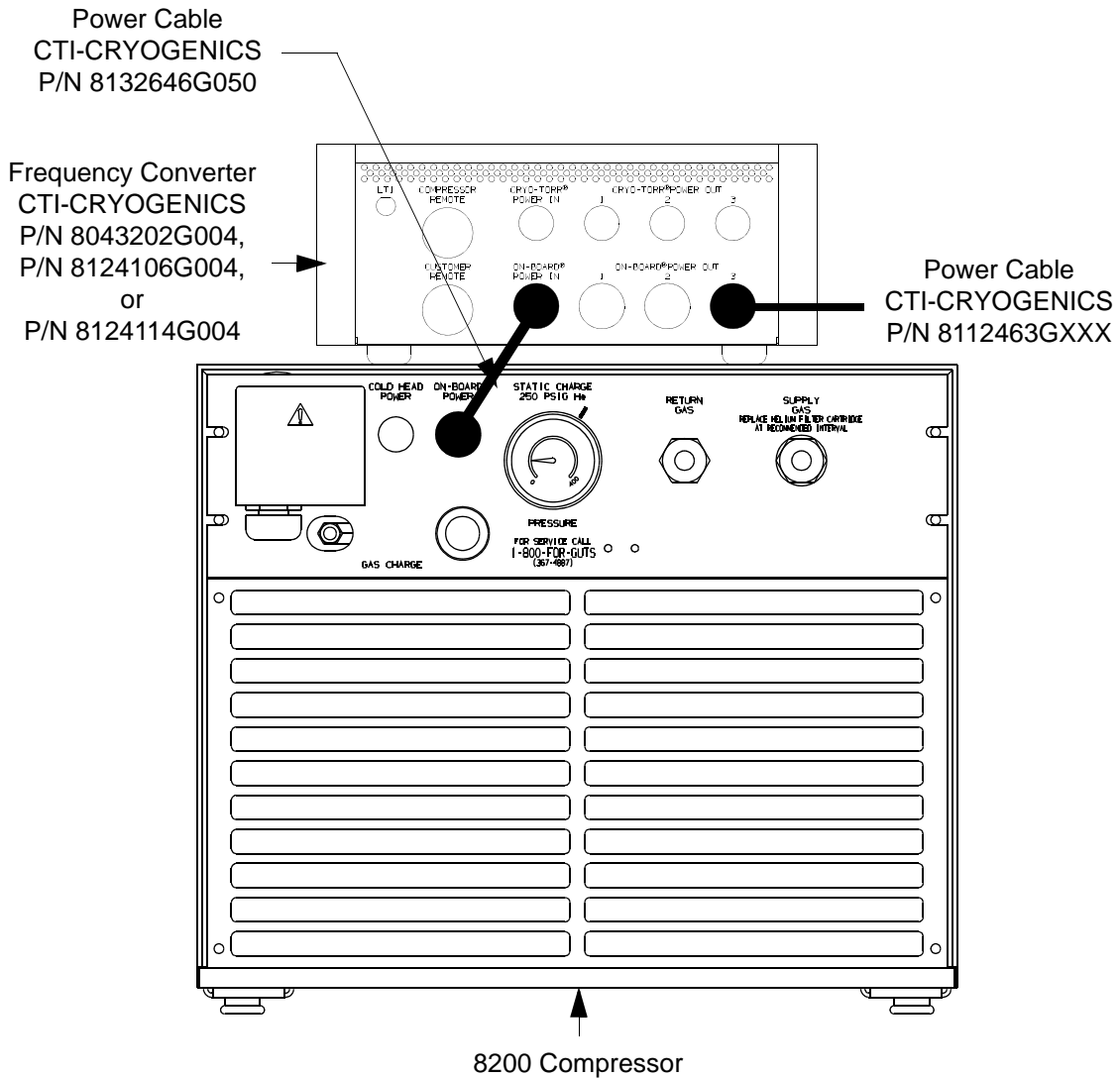

Figure 3-3: 8200 Single Phase Compressor with an On-Board Cryopump

---

## 8200 Single Phase Compressor with Cryo-Torr Cryopumps

This procedure involves the following components:

- 8200 Single Phase, Water or Air Cooled Compressor
- Frequency Converter, CTI-CRYOGENICS P/N 8043202G003, 8124106G003, or 8124114G003, which includes power cable CTI-CRYOGENICS P/N 8043072G050
- Cryo-Torr Cryopumps

**NOTE:** *If installing a new 8200 Compressor along with the Frequency Converter, refer to the **8200 Compressor Installation, Operation, and Service** manual CTI-CRYOGENICS P/N 8040353 for information on setting the control module to the proper operating voltage range before installing the Frequency Converter.*

1. Carefully place the Frequency Converter on top of the 8200 Compressor as shown in Figure 2-4.
2. Connect the Cryo-Torr Cryopump power cable CTI-CRYOGENICS P/N 8032222GXXX between one of the CRYO-TORR POWER OUT connectors on the rear panel of the Frequency Converter and the connector on the Cryo-Torr Cryopump as shown in Figure 2-4.
3. Connect the power cable CTI-CRYOGENICS P/N 8043072G050 between the CRYO-TORR POWER IN connector on the rear panel of the Frequency Converter and the COLD HEAD POWER connector on the rear panel of the 8200 compressor as shown in Figure 2-4.

**NOTE:** *Make sure the Frequency Selector Switch is set to the 60Hz position. Failure to do so will result in improper system operation.*

4. Set the Frequency Selector Switch on the front panel of the 8200 compressor to the 60Hz position.
5. Set the Power Switch on the front panel of the 8200 compressor to the ON position.

**CAUTION**

Allow a 1.0 inch minimum space above the top of the Frequency Converter for adequate ventilation

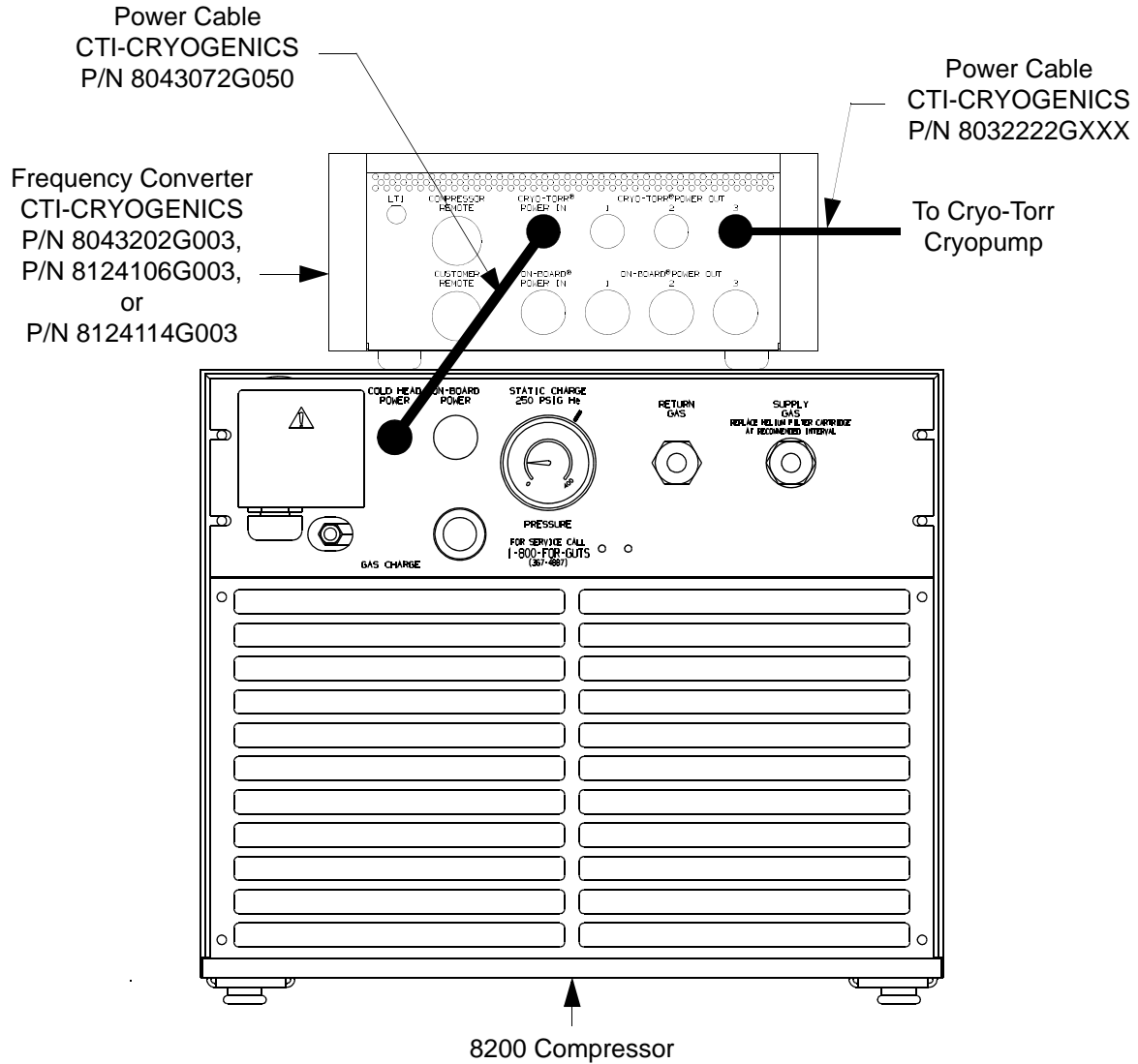

Figure 3-4: 8200 for Single Phase Compressor with Cryo-Torr Cryopumps

---

## 8200 Three Phase Compressor with an On-Board Cryopump

This procedure involves the following components:

- 8200 Three Phase Compressor
- Frequency Converter, CTI-CRYOGENICS P/N 8043202G002, 8124106G002, or 8124114G002, which includes On-Board Cryopump power cable CTI-CRYOGENICS P/N 8112463G050
- One On-Board Cryopump

**NOTE:** *If installing a new 8200 Compressor along with the Frequency Converter, refer to the **8200 Compressor Installation, Operation, and Service** manual CTI-CRYOGENICS P/N 8040353 for information on setting the control module to the proper operating voltage range before installing the Frequency Converter.*

1. Carefully place the Frequency Converter on top of the 8200 Compressor as shown in Figure 2-5.
2. Connect the On-Board Cryopump power cable CTI-CRYOGENICS P/N 8112463GXXX between one of the ON-BOARD POWER OUT connectors on the rear panel of the Frequency Converter and the POWER IN connector on the On-Board Cryopump Module as shown in Figure 2-5.
3. Connect the power cable CTI-CRYOGENICS P/N 8112463G050 (supplied) between the ON-BOARD POWER IN connector on the rear panel of the Frequency Converter and the ON-BOARD POWER connector on the rear panel of the 8200 compressor as shown in Figure 2-5.
4. Set the Power Switch on the front panel of the 8200 compressor to the ON position.

**CAUTION**

Allow a 1.0 inch minimum space above the top of the Frequency Converter for adequate ventilation

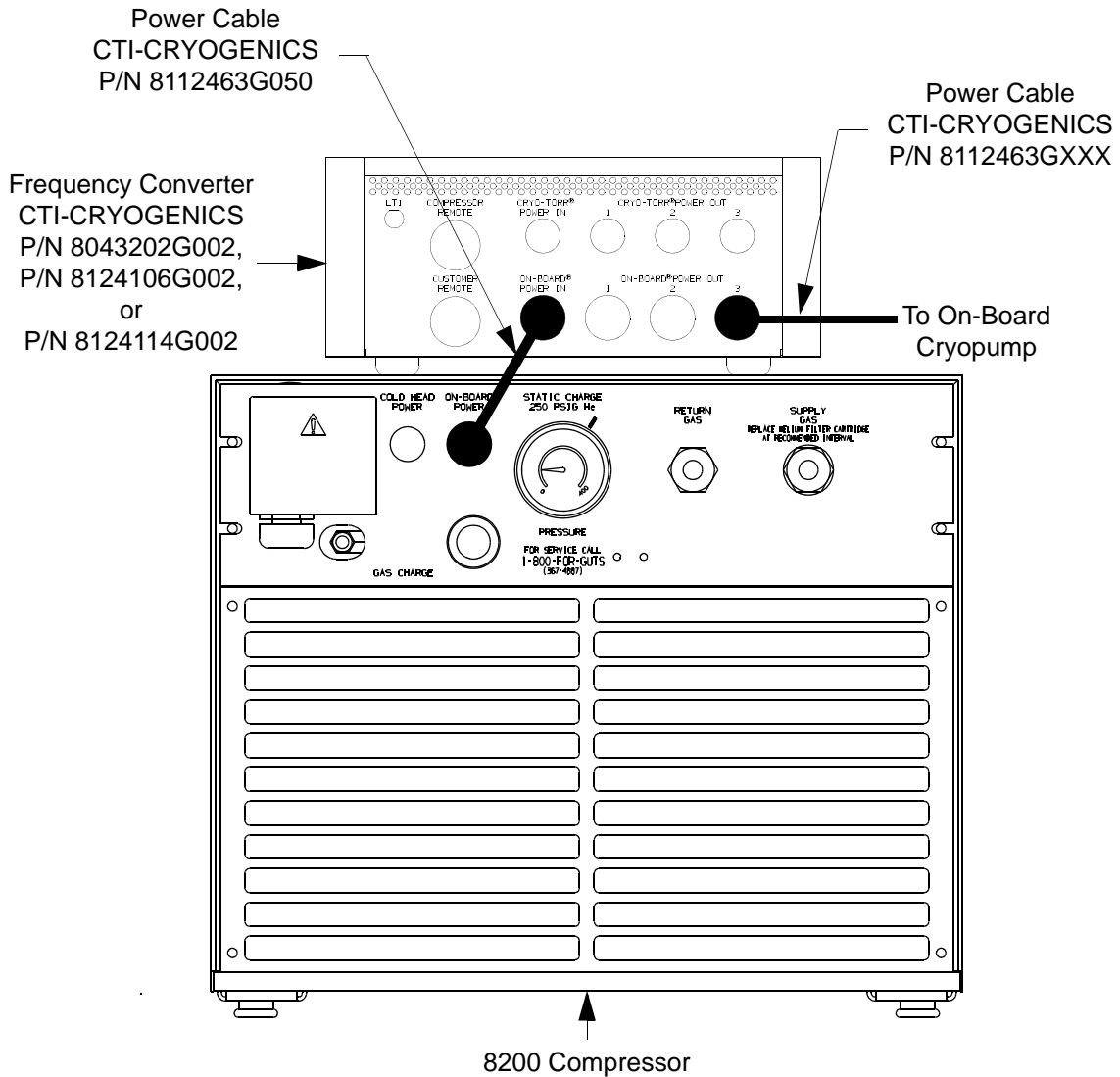

Figure 3-5: 8200 Three-Phase Compressor with an On-Board Cryopump

---

## 8200 Three Phase Compressor with Cryo-Torr Cryopumps

This procedure involves the following components:

- 8200 Three Phase Water Cooled Compressor
- Frequency Converter, CTI-CRYOGENICS P/N 8043202G001, 8124106G001, 8124114G001, which includes Frequency Converter Cable Kit, CTI-CRYOGENICS P/N 8080005K012
- Cryo-Torr Cryopumps

**NOTE:** *NOTE: An 8200 Three Phase Compressor does not support Cryo-Torr Cryopump Remote ON/OFF capability.*

**NOTE:** *If installing a new 8200 Compressor along with the Frequency Converter, refer to the **8200 Compressor Installation, Operation, and Service** manual CTI-CRYOGENICS P/N 8040353 for information on setting the control module to the proper operating voltage range before installing the Frequency Converter.*

1. Carefully place the Frequency Converter on top of the 8200 Compressor as shown in Figure 2-6.
2. Connect the Cryo-Torr Cryopump power cable CTI-CRYOGENICS P/N 8032222GXXX between one of the CRYO-TORR POWER OUT connectors on the rear panel of the Frequency Converter and the connector on the Cryo-Torr Cryopump as shown in Figure 2-6.
3. Connect the power cable CTI-CRYOGENICS P/N 8043054G050 between the CRYO-TORR POWER IN connector on the rear panel of the Frequency Converter and the COLD HEAD POWER connector on the rear panel of the 8200 compressor as shown in Figure 2-6.
4. Set the Power Switch on the front panel of the 8200 compressor to the ON position.

**CAUTION**

Allow a 1.0 inch minimum space above the top of the Frequency Converter for adequate ventilation

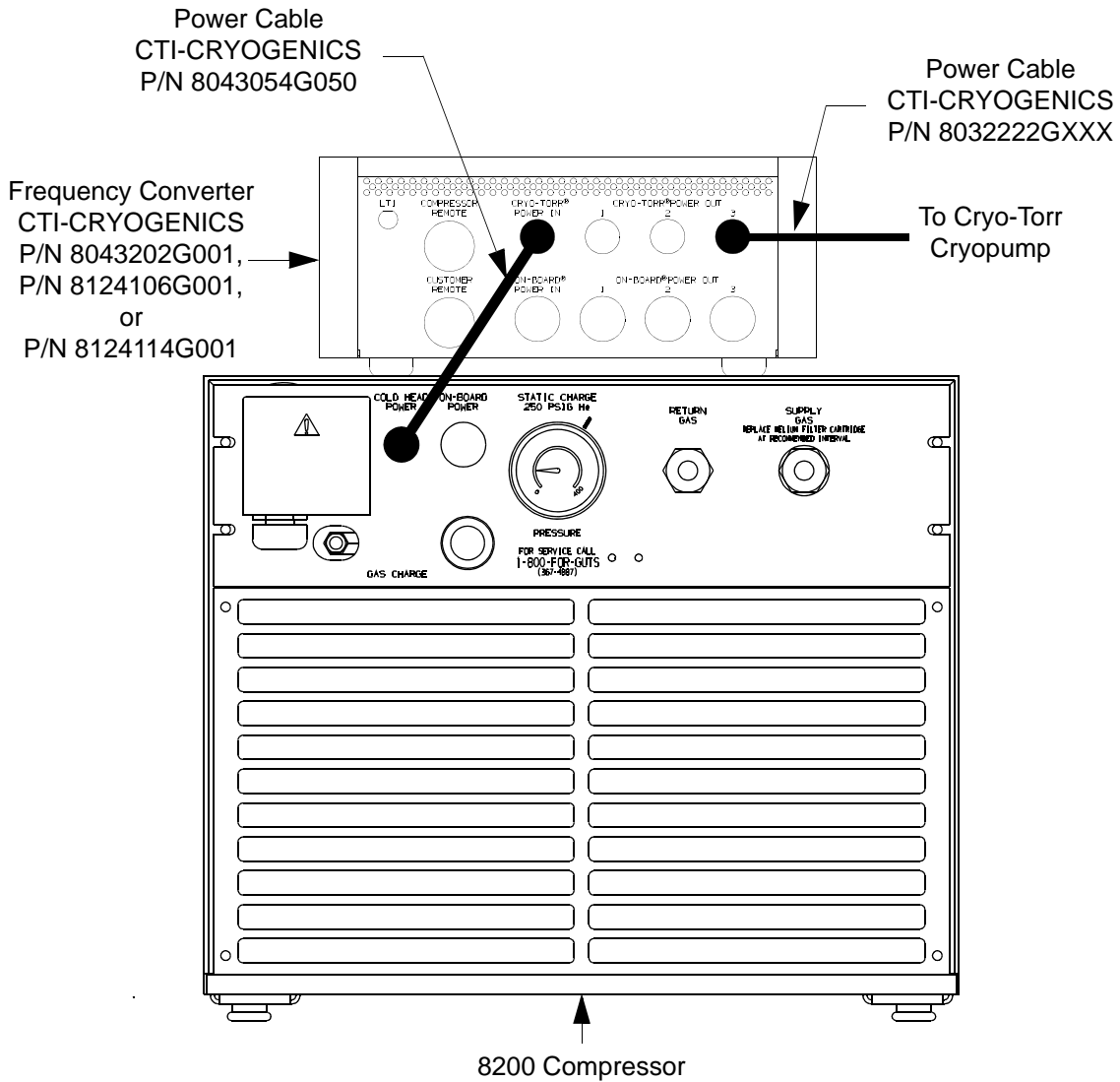

Figure 3-6: 8200 Three-Phase Compressor with Cryo-Torr Cryopumps



---

## 8510 Compressor with On-Board Cryopumps

This procedure involves the following components:

- 8510 Low-Voltage Compressor, CTI-CRYOGENICS P/N 8031315
- Frequency Converter, CTI-CRYOGENICS P/N 8043202G002, 8124106G002, or 8124114G002, which includes On-Board Power Cable, CTI-CRYOGENICS P/N 8112463G050
- On-Board Cryopumps

**NOTE:** *NOTE: If installing a new 8510 Compressor along with the Frequency Converter, refer to the **8510 Compressor Installation, Operation, and Service** manual CTI-CRYOGENICS P/N 8040232 for information on setting the control module to the proper operating voltage range before installing the Frequency Converter.*

1. Carefully place the Frequency Converter on top of the 8510 Compressor as shown in Figure 2-7.
2. Connect the three On-Board power cables to the ON-BOARD POWER OUT outputs 1, 2 and 3 on the Frequency Converter.

**NOTE:** *Make sure the On-Board Cryopump Power cable is connected to COLD HEAD 3 output on the compressor in step 3. The CUSTOMER REMOTE capability will not function if connected to output 1 or 2.*

3. Connect the On-Board Cryopump power cable, P/N 8112463G050 (supplied), between the ON-BOARD POWER IN, input on the converter and the COLD HEAD 3 output on the compressor.
4. Set the Power Switch on the front panel of the 8510 compressor to the ON position.

**CAUTION**

Allow a 1.0 inch minimum space above the top of the Frequency Converter for adequate ventilation

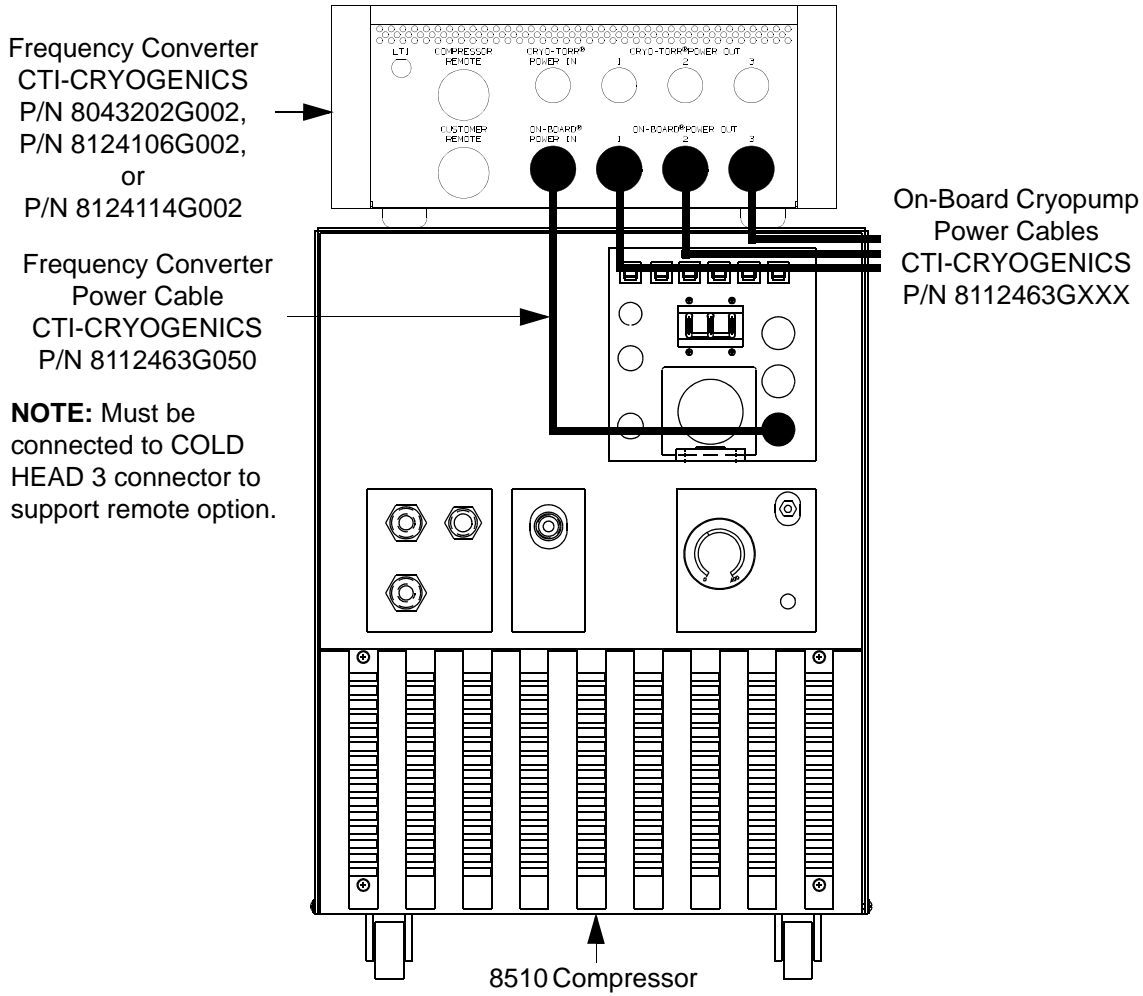

*Figure 3-7: 8510 Compressor with On-Board Cryopumps*

---

## 8500 Compressor with On-Board Cryopumps

This procedure involves the following components:

- 8500 Compressor, CTI-CRYOGENICS P/N 8031348G001 or G002
- Frequency Converter, CTI-CRYOGENICS P/N 8043202G002, 8124106G002, or 8124114G002, which includes Frequency Converter Cable Kit, CTI-CRYOGENICS P/N 8080005K012 8011 Compressor Controller
- On-Board Cryopumps

**NOTE:** *NOTE: If installing a new 8500 Compressor along with the Frequency Converter, refer to the **8500 Compressor Installation, Operation, and Service** manual CTI-CRYOGENICS P/N 8040324 for information on setting the control module to the proper operating voltage range before installing the Frequency Converter.*

**NOTE:** *If installing a new 8011 Controller along with the Frequency Converter, refer to the **8011 Controller and 8011 Control Module** manual CTI-CRYOGENICS P/N 8040309 for proper setup before installing the Frequency Converter.*

1. Carefully place the 8011 Controller on top of the 8500 compressor as shown in Figure 2-8.
2. Carefully place the Frequency Converter on top of the 8011 Controller as shown in Figure 2-8.

**NOTE:** *NOTE: Make sure the cryopump cable is connected to COLD HEAD 3 output on the compressor. The CUSTOMER REMOTE capability will not function if connected to output 1 or 2.*

3. Connect the cryopump cable CTI-CRYOGENICS P/N 8043054P050 between COLD HEAD 3 connector on the 8500 Compressor and 1 IN connector on the 8011 Controller.
4. Connect the On-Board power cable CTI-CRYOGENICS P/N 8112463G050 between the 1 OUT connector on the 8011 Controller and the ON-BOARD POWER IN connector on the Frequency Converter.
5. Connect the On-Board Cryopump power cables CTI-CRYOGENICS P/N 8112463GXXX between the ON-BOARD POWER OUT connectors on the Frequency Converter and the On-Board Cryopumps.
6. Set the Power Switch on the front panel of the 8500 compressor to the ON position.

**CAUTION**

Allow a 1.0 inch minimum space above the top of the Frequency Converter for adequate ventilation

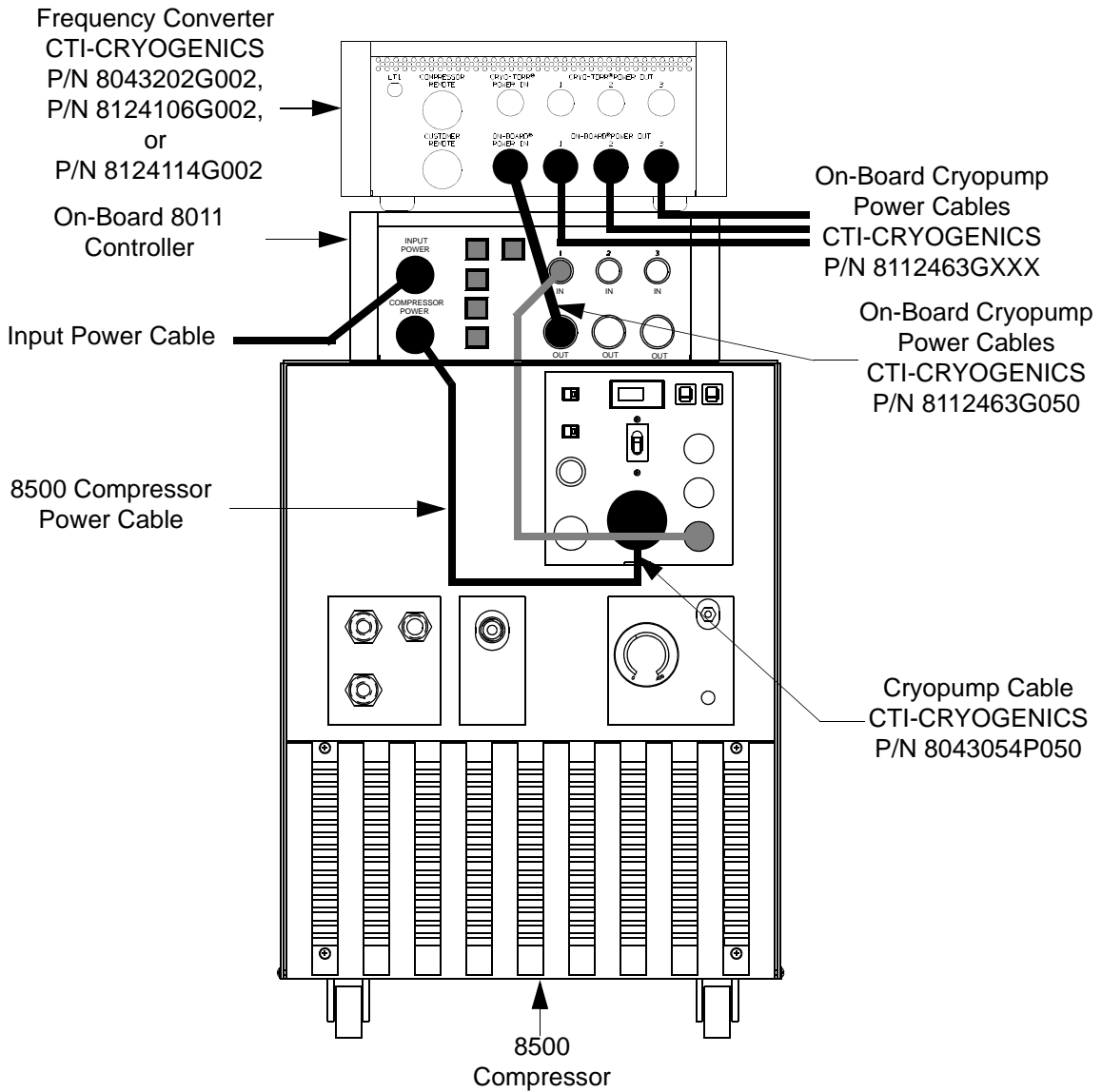

Figure 3-8: 8500 Compressor with an On-Board Cryopump

---

## 8500 Compressor with Cryo-Torr Cryopumps

This procedure involves the following components:

- 8500 Compressor, CTI-CRYOGENICS P/N 8031348G001 or G002
- Frequency Converter, CTI-CRYOGENICS P/N 8043202G001, 8124106G001, or 8124114G001, which includes Frequency Converter Cable Kit, CTI-CRYOGENICS P/N 8080005K012 which can be used with an optional remote
- Cryo-Torr Cryopumps

**NOTE:** *If installing a new 8500 Compressor along with the Frequency Converter, refer to the **8500 Compressor Installation, Operation, and Service** manual CTI-CRYOGENICS P/N 8040324 for information on setting the control module to the proper operating voltage range before installing the Frequency Converter.*

1. Carefully place the Frequency Converter on top of the 8500 Compressor as shown in Figure 2-9.
2. Connect the cables to the corresponding CRYO-TORR POWER outputs 1, 2 and 3 on the Frequency Converter.
3. Connect the standard remote cable between the COMPRESSOR REMOTE input on the converter and the REMOTE input on the compressor (optional).
4. Connect the Power Cable between the CRYO-TORR POWER IN input on the converter and the COLD HEAD 3 output on the compressor.

**NOTE:** *Make sure the cryopump cable is connected to COLD HEAD 3 output on the compressor. The CUSTOMER REMOTE capability will not function if connected to output 1 or 2.*

5. Set the Power Switch on the front panel of the 8500 compressor to the ON position.

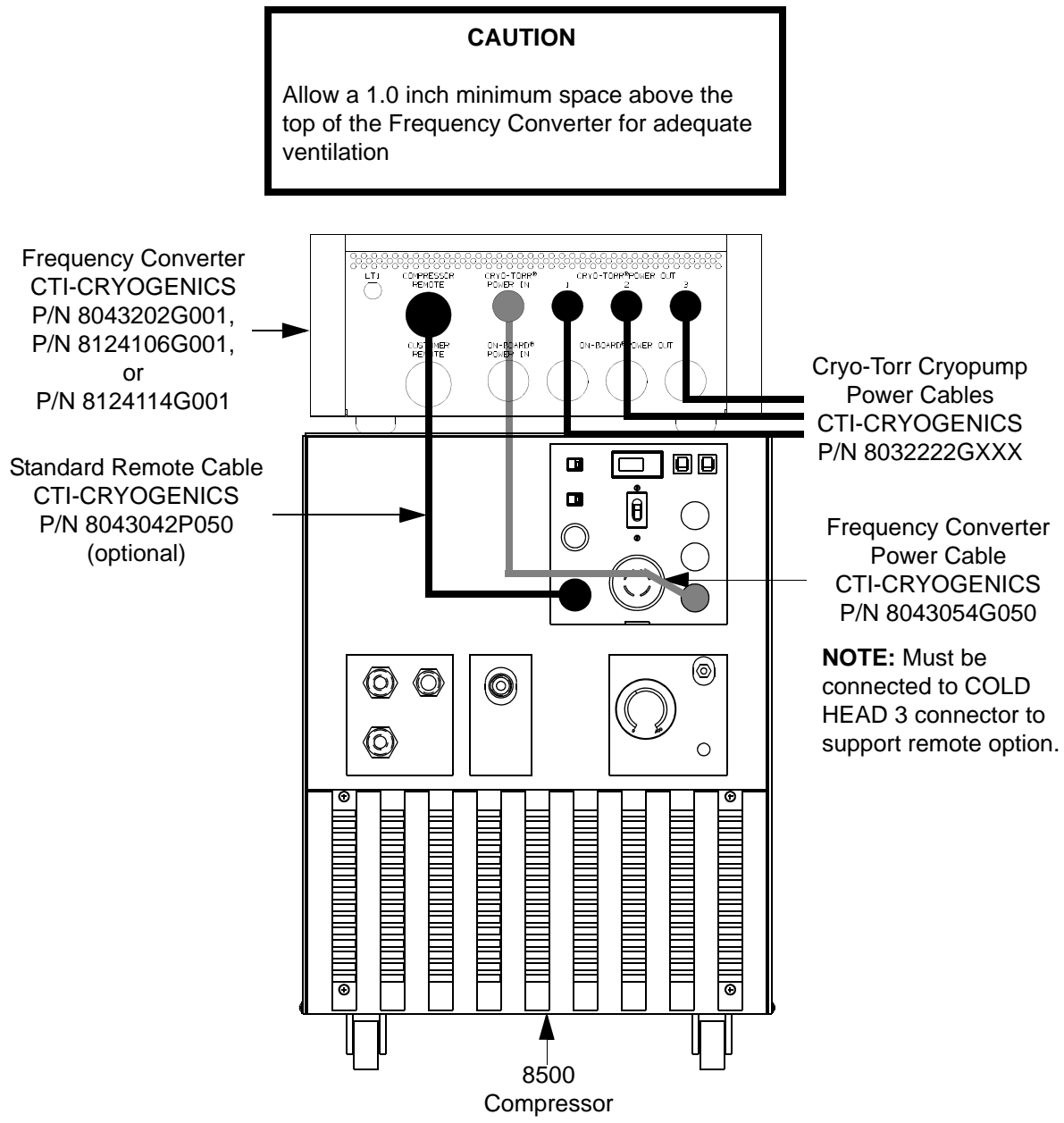

*Figure 3-9: 8500 Compressor with Cryo-Torr Cryopumps*

---

## 1020R Compressor with On-Board Cryopumps

This procedure involves the following components:

- 1020R Compressor, CTI-CRYOGENICS P/N 8031023G001 and G002
- On-Board 8011 Controller
- Frequency Converter, CTI-CRYOGENICS P/N 8043202G002, 8124106G002, or 8124114G002, which includes On-Board Power Cable, CTI-CRYOGENICS P/N 8112463G050
- On-Board Cryopumps

**NOTE:** *If installing a new 1020R Compressor along with the Frequency Converter, refer to the **1020R Compressor Installation, Operation, and Service** manual CTI-CRYOGENICS P/N 8040274 for information on setting the control module to the proper operating voltage range before installing the Frequency Converter.*

**NOTE:** *If installing a new 8011 Controller along with the Frequency Converter, refer to the **8011 Controller and 8011 Control Module** manual CTI-CRYOGENICS P/N 8040309 for proper setup information before installing the Frequency Converter.*

1. Carefully place the On-Board 8011 Controller on top of the 1020R Compressor as shown in Figure 2-10.
2. Carefully place the Frequency Converter on top of the 8011 Controller as shown in Figure 2-10.
3. Connect the three On-Board cryopump power cables CTI-CRYOGENICS P/N 81122463GXXX into the ON-BOARD POWER OUT connectors 1, 2 and 3 on the Frequency Converter as shown in Figure 2-10.
4. Connect the cryopump power cable, hard wired to the compressor, to the COLD HEADS 1 IN connector on the 8011 Controller.
5. Connect the On-Board power cable, CTI-CRYOGENICS P/N 8112463G050 (supplied) to the On-Board POWER IN input on the converter and the CRYOPUMPS 1 OUT connector on the 8011 Controller.
6. Turn on SYSTEM POWER at the compressor.

**CAUTION**

Allow a 1.0 inch minimum space above the top of the Frequency Converter for adequate ventilation

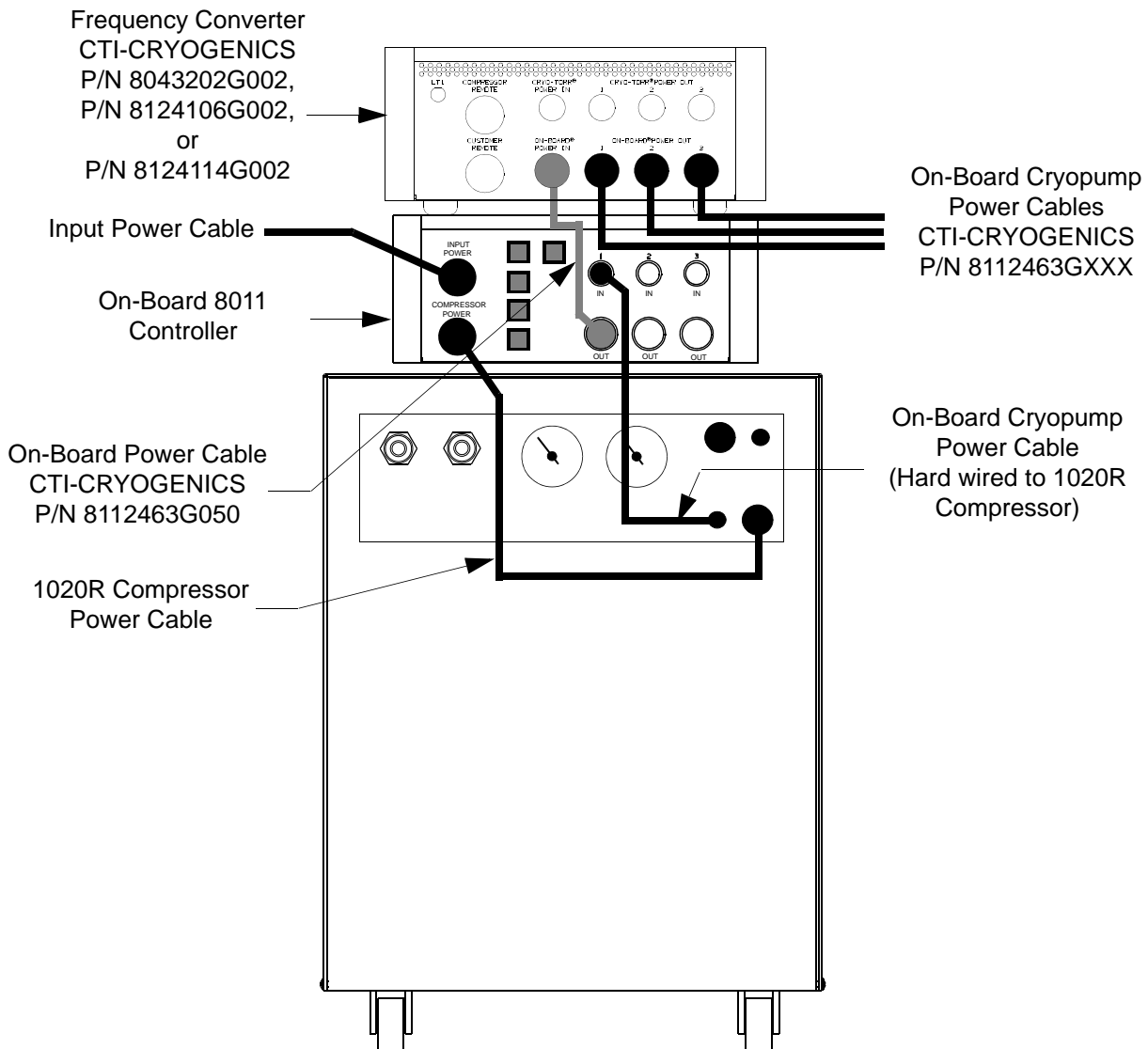

Figure 3-10: 1020R Compressor with On-Board Cryopumps



---

## 1020R Compressor with Cryo-Torr Cryopumps

This procedure involves the following components:

- 1020R Compressor, CTI-CRYOGENICS P/N 8031023G001 and G002
- Frequency Converter, CTI-CRYOGENICS P/N 8043202G001, 8124106G001, or 8124114G001, which includes the Frequency Converter Cable Kit CTI-CRYOGENICS P/N 8080005K012
- Cryo-Torr Cryopumps

**NOTE:** *NOTE: If installing a new 1020R Compressor along with the Frequency Converter, refer to the **1020R Compressor Installation, Operation, and Service manual** CTI-CRYOGENICS P/N 8040274 for information on setting the control module to the proper operating voltage range before installing the Frequency Converter.*

1. Carefully place the Frequency Converter on top of the 1020R Compressor as shown in Figure 2-11.
2. Connect the three Cryo-Torr cryopump power cables CTI-CRYOGENICS P/N 8032222GXXX into the CRYO-TORR POWER OUT connectors 1, 2 and 3 on the Frequency Converter as shown in Figure 2-11.
3. Connect the Cryo-Torr Cryopump Power Cable to the CRYO-TORR POWER IN connector on the Frequency Converter.
4. Turn on SYSTEM POWER at the compressor.

**CAUTION**

Allow a 1.0 inch minimum space above the top of the Frequency Converter for adequate ventilation

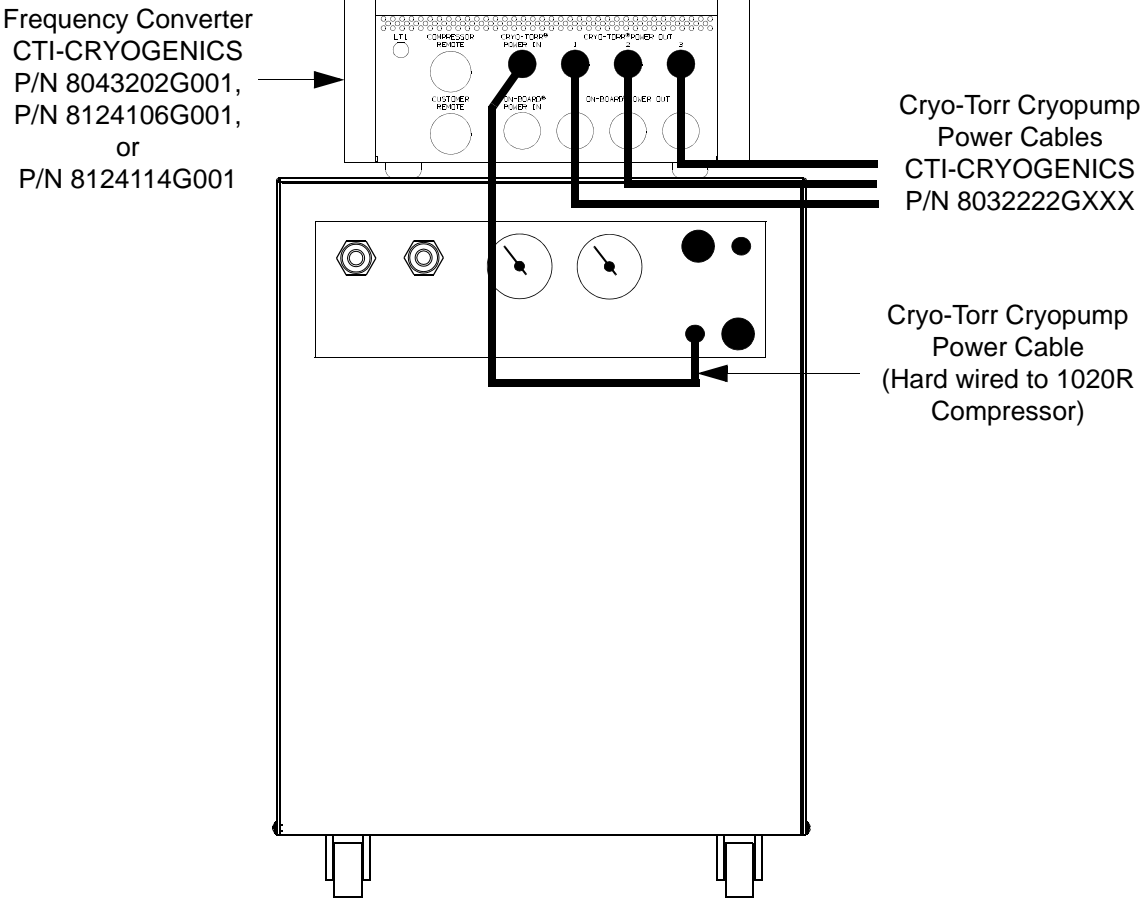

*Figure 3-11: 1020R Compressor with Cryo-Torr Cryopumps*

## Overview

The following appendices are included to provide the user with a single location for specific information related to the Brooks Automation Product.

## Contents

Overview .....	4-1
Appendix A: Customer Support Information .....	4-2
Customer Support Center Locations .....	4-2
Guaranteed Up-Time Support (GUTS <sup>®</sup> ) .....	4-2
Product Information .....	4-2
E-mail .....	4-2

---

## Appendix A: Customer Support Information

### Customer Support Center Locations

To locate a Customer Support Center near you, please visit our website *www.brooks.com* on the world wide web and select *CONTACT* on the home page.

### Guaranteed Up-Time Support (GUTS®)

For 24-hour, 7-day per week Guaranteed Up-Time Support (GUTS) dial:

**1 800-367-4887** - Inside the United States of America

**+1 508-337-5599** - Outside the United States of America

### Product Information

Please have the following information available when calling so that we may assist you:

- Product Part Number
- Product Serial Number
- Product Application
- Specific Problem Area
- Hours of Operation
- Equipment Type
- Vacuum System Brand/Model/Date of Manufacture

### E-mail

For your convenience, you may also e-mail us at:

[techsupport@brooks.com](mailto:techsupport@brooks.com)